

智能阀门定位器 IP7000 系列使用说明书

Intelligent Valve Positioner IP7000 Series User's Manual

(安装使用前请仔细阅读使用说明书)



使用说明书目录

IP7000 系列智能阀门定位器

1. 概述	1
2. 一键自动初始化	1
3. 选型及订货数据	2
4. 主要技术指标	3
5. 接口说明	6
6. 机械尺寸	8
6.1. 外形尺寸	8
6.2. 安装支架尺寸	9
6.3. 磁体配件尺寸	12
7. 安装	14
7.1. 直行程	14
7.2. 角行程	16
7.3. 安装注意事项	19
7.4. 位置反馈模块	19
8. 操作	22
8.1. 界面描述	22
8.2. 主界面显示和操作	23
8.3. 菜单和功能	24
8.3.1. 菜单显示和操作	24
8.3.2. 功能描述和操作	24
8.3.2.1. TYPE	24
8.3.2.2. INITA	25
8.3.2.3. INITM	25
8.3.2.4. CAL	25
8.3.2.5. SDIR	26
8.3.2.6. CHAR	27
8.3.2.7. FREE	28
8.3.2.8. DB	29
8.3.2.9. LIM	29
8.3.2.10. YDIR	30
8.3.2.11. CUT	30

8.3.2.12.	POS	31
8.3.2.13.	FACT	33
8.3.2.14.	WP	33
8.3.2.15.	ACT	33
8.3.2.16.	REC	33
8.3.2.17.	LCD	33
8.3.2.18.	DIAG	34
8.3.2.19.1.	PST	34
8.3.2.19.	SPLIT	35
8.3.2.20.	EXT	35
8.3.3.	初始化过程错误提示	36
8.3.4.	菜单选项或功能无法访问提示	36
8.3.5.	菜单功能选项汇总说明	36
8.4.	HART DD 文件和 DTM 文件说明	38
8.4.1.	设备动态变量说明	38
8.4.2.	设备自定义功能说明	38
8.5.	反馈信号	41
8.6.	流量调节	41
9.	故障检修	43
10.	保修条款	44



1. 概述

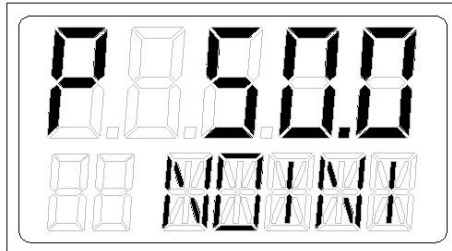

IP7000 系列智能阀门定位器和气动执行器配套使用。通过接收来自控制系统的 4-20mA DC 电流信号得到阀位控制设定值，同时采集位置传感器信号得到实际的阀位值，两者通过控制软件的计算处理，从而控制气动执行机构的进气和排气，驱动阀位到达设定点。

2. 一键自动初始化

1. 定位器安装前请详细阅读第 7 章节的安装说明。按照所描述的安装要求来安装定位器。请注意一些安装要点。
2. 将定位器安装到阀门上后，接上气源和电气线缆。确保气源压力能完全打开阀门。通过输入 4-20mA 信号给定位器上电。
3. 定位器上电后，系统在没完成初始化功能前处于未初始化状态。显示标志为 NOINI，界面第一行显示传感器百分比值。如下图所示。



在此状态下，操作   键可打开或关闭阀门。将阀门全开和全闭，观察界面上显示的传感器百分比值。确保在整个阀门行程范围内，传感器百分比值单调变化。否则，需要重新调整安装位置。另外，要求传感器最小最大百分比差值大于 15%。

4. 定位器出厂前已设置好执行机构类型。用户只需一键执行自动初始化 (INITA) 功能来完成对阀门的匹配。在初始界面 (NOINI) 或手自动模式界面长按  键 3 秒左右开始运行自动初始化。初始化完成后，LCD 上显示 FINSH，按  键退出。退出后，系统进入手动模式界面，再次按  键可切换到自动模式。此时用户可通过 4-20mA 信号来控制阀门开度。自动初始化过程中由于某些原因，系统会在功能选项栏显示错误提示。并中断初始化。错误提示说明及处理方法详见 8.3.3 章节。

3. 选型及订货数据

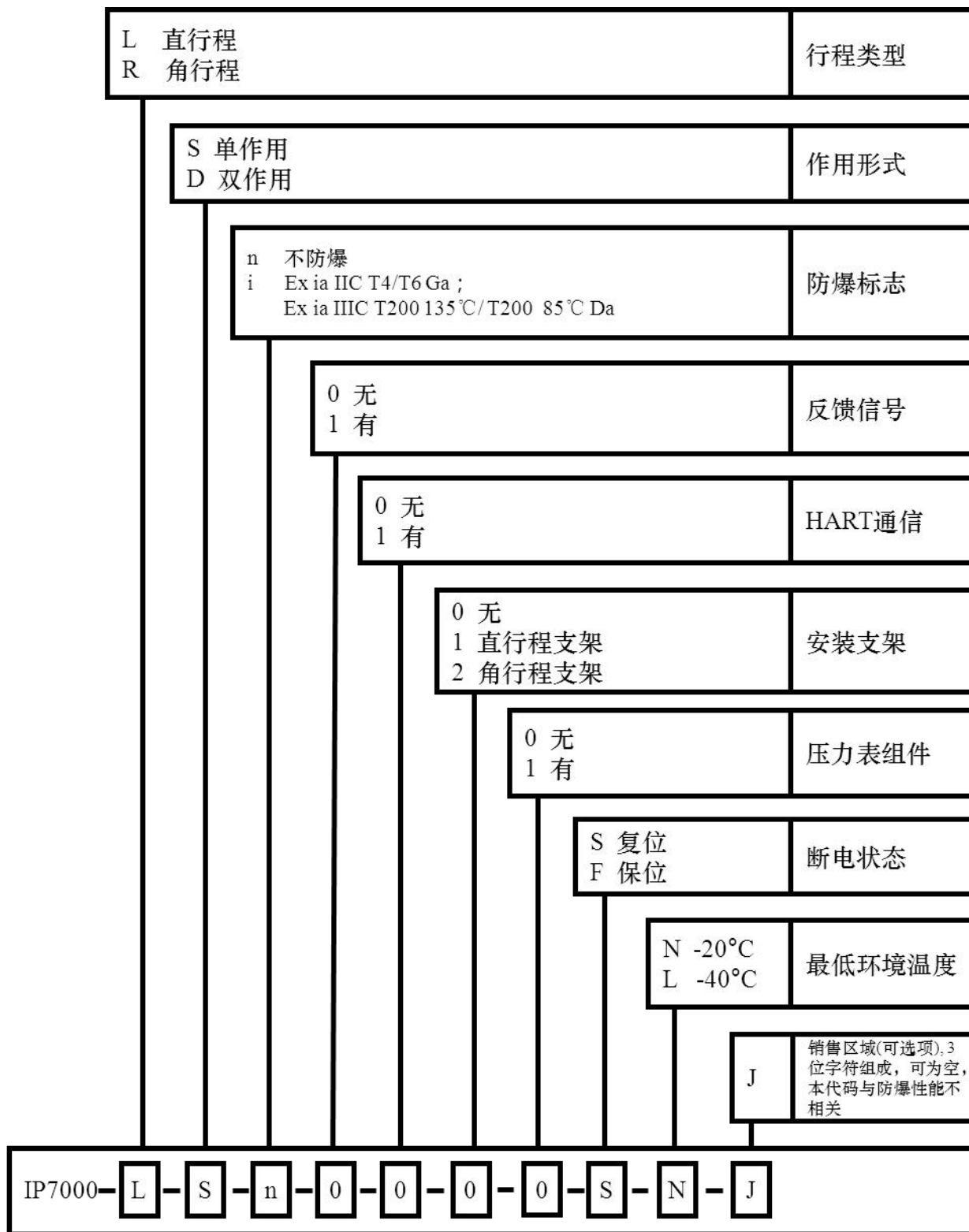

4. 主要技术指标

外壳材质	铝合金
信号输入	4-20mA DC, 空载电压:15-24V DC
最小工作电流	3.8mA
输入阻抗	120Ω
环境温度	非防爆常规版本: -20°C ~ +80°C 非防爆低温版本: -40°C ~ +80°C 防爆常规版本: -20°C ~ +80°C (T4) , -20°C ~ +40°C (T6) 防爆低温版本: -40°C ~ +80°C (T4) , -40°C ~ +40°C (T6) 设备显示屏在-20°C 以下会显示迟钝或不显示。
气源要求	符合 ISO 8573-1 <ul style="list-style-type: none"> ● 固体颗粒大小和密度 3 级 ● 露点 3 级 ● 含油量 3 级
抗振动性	0.15mm, 10Hz-60Hz, 20 次循环/轴 20m/s ² , 60Hz-500Hz, 20 次循环/轴 整个控制阀连续运行时的推荐范围≤20 m/s ² , 无谐振峰值
气源压力	0.14-0.7MPa
流量	<ul style="list-style-type: none"> ● 进气 2 bar 4.8 Nm³/h 4 bar 8.0 Nm³/h 6 bar 11.2 Nm³/h ● 排气(复位) 2 bar 5.9 Nm³/h 4 bar 9.8 Nm³/h 6 bar 13.7 Nm³/h ● 排气(保位) 2 bar 6.6 Nm³/h 4 bar 11.1 Nm³/h 6 bar 15.6 Nm³/h
稳态耗气量	≤0.4 L/min
基本误差	≤1.0%

回差	≤1.0%
电气接口	1/2NPT(默认)或 M20x1.5, 其他螺纹规格请与销售沟通
气动接口	1/4NPT(默认)或 G1/4, 其他螺纹规格请与销售沟通
重量	2.0 kg
防护等级	IP69K
防爆标志	Ex ia IIC T4/T6 Ga; Ex ia IIIC T200 135°C / T200 85°C Da;

本安电气参数:

回路名称	最高输入电压 U_i (V)	最大输入电流 I_i (mA)	最大输入功率 P_i (W)	最大内部等效参数	
				C_i (nF)	L_i (mH)
4~20mA 设定	28	93	0.66	近似为 0	近似为 0
4~20mA 输出	28	93	0.66	近似为 0	近似为 0

特殊限制使用条件:

1) 产品使用环境温度范围:

产品最低使用环境温度为: -40°C 。

产品最高使用环境温度与温度组别/最高表面温度之间的关系见下表:

最高使用环境温度 ($^{\circ}\text{C}$)	温度组别/最高表面温度
$+80^{\circ}\text{C}$	T4/T ₂₀₀ 135 $^{\circ}\text{C}$
$+40^{\circ}\text{C}$	T6/T ₂₀₀ 85 $^{\circ}\text{C}$

2) 当产品安装于要求 EPL Ga 级的场所时, 用户须采取有效措施防止产品外壳由于冲击或摩擦引起的点燃危险。

3) 应至少采取以下措施避免静电电荷在产品外壳上积聚:

a 控制环境相对湿度以将静电产生降到最小。

b 不得干擦或吹扫产品外壳表面, 以防静电引燃危险。

4) 关联装置应优先选用隔离式安全栅; 如选用齐纳式安全栅, 应符合 GB 3836.15-2024 标准关于本安电路接地的要求。

注意事项:

产品的安装、使用和维护应同时遵守产品使用说明书及下列相关标准的要求:

GB/T 3836.13-2021 爆炸性环境 第 13 部分: 设备的修理、检修、修复和改造

GB 3836.15-2024 爆炸性环境 第 15 部分: 电气装置设计、选型、安装规范

GB 3836.16—2024 爆炸性环境 第 16 部分：电气装置检查与维护规范

GB/T 3836.18—2024 爆炸性环境 第 18 部分：本质安全电气系统

GB 15577—2018 粉尘防爆安全规程

GB 50257—2014 电气装置安装工程爆炸和火灾危险环境电气装置施工及验收规范

5. 接口说明



图 1. 接口说明

电气接口	描述
IN+	4-20 mA 设定信号 +
IN-	4-20 mA 设定信号 -
OUT+	反馈信号模块 18-30 V DC +
OUT-	反馈信号模块 4-20mA 输出
*	两个接口相互连接后设备处于低阻抗模式(低阻抗模式下, HART 通信功能将失效)

备注: 分体式 OUT1 和 OUT2 堵住不用。

气动接口	描述
SUP	气源进入
OUT1	先导气口 1
OUT2	先导气口 2, 双作用时使用

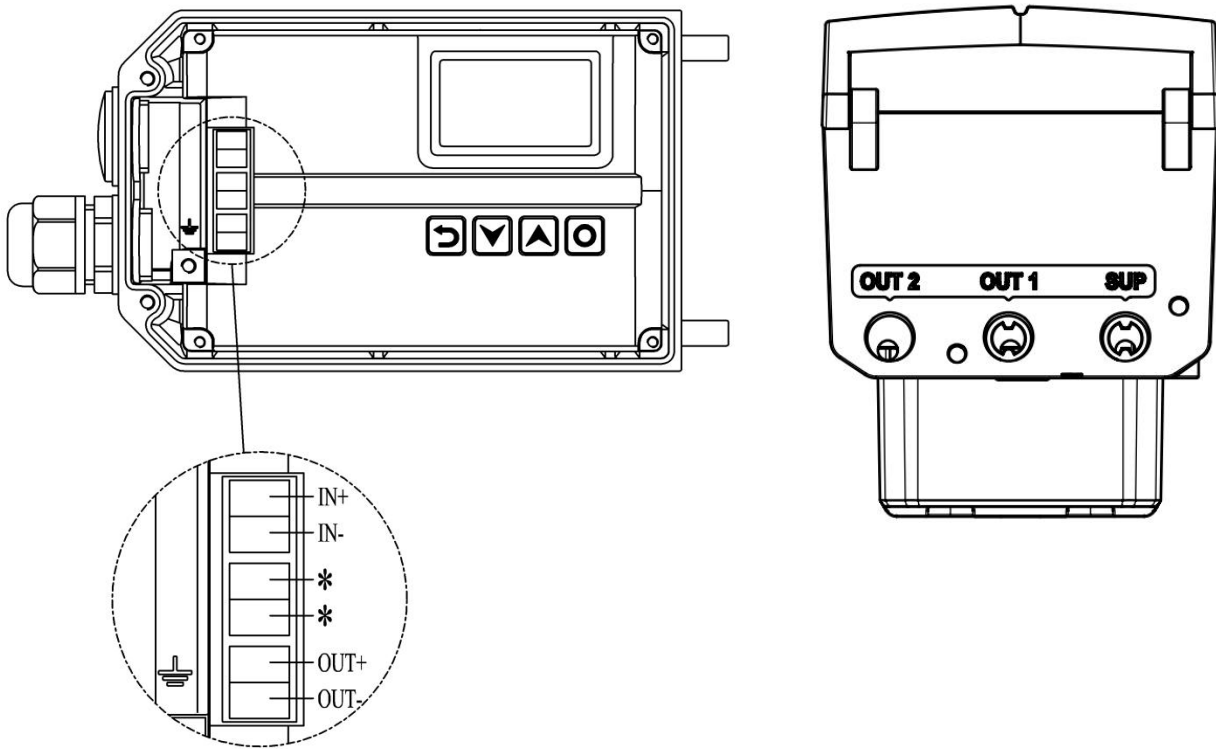
注意：

- 电气线缆必须用屏蔽双绞线或屏蔽线。并将线缆屏蔽层一端连接设备壳体内 \perp 处的螺钉，另一端连接大地。从而使设备有效接地，防止电磁干扰。
- 电气线缆铺设要远离强磁场环境。
- 请在设备断电情况下连接或拆卸电气线缆。
- 如果输入信号有衰减，而用户不需要 HART 通信功能，可以尝试将定位器设置成低阻抗模式。将图 1 所示的 2 个 * 标记的未定义电气接口通过 1 根导线相互连接，使定位器处于低阻抗模式。
- 如果要使用定位器的分程控制功能，必须使用直流信号隔离器将 1 路 4-20mA 设定信号转换成 2 路 4-20mA 设定信号，再分别连接到 2 台定位器上。定位器设置成低阻抗模式。

HART 通信接线方式：

将 HART 调制解调器或 HART 手操器的两根信号线分别接到 4-20 mA 设定信号的正负极上。

6. 机械尺寸

6.1. 外形尺寸



图 2. 外形尺寸

6.2. 安装支架尺寸



图 3. 常规型直行程安装支架

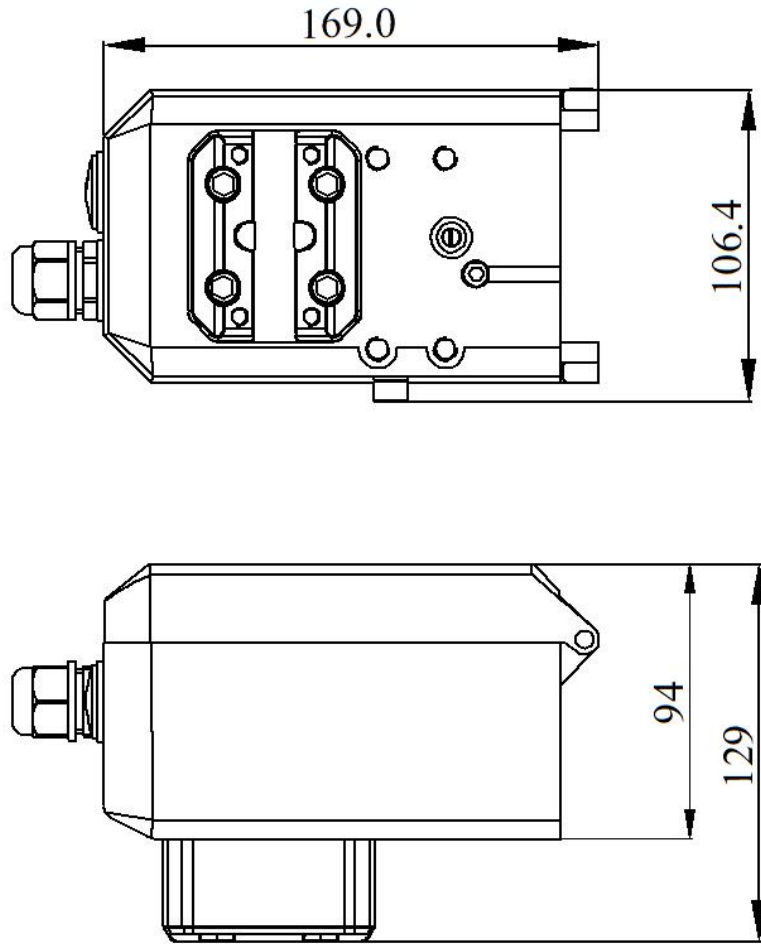

图 4. 角行程安装支架 A 型

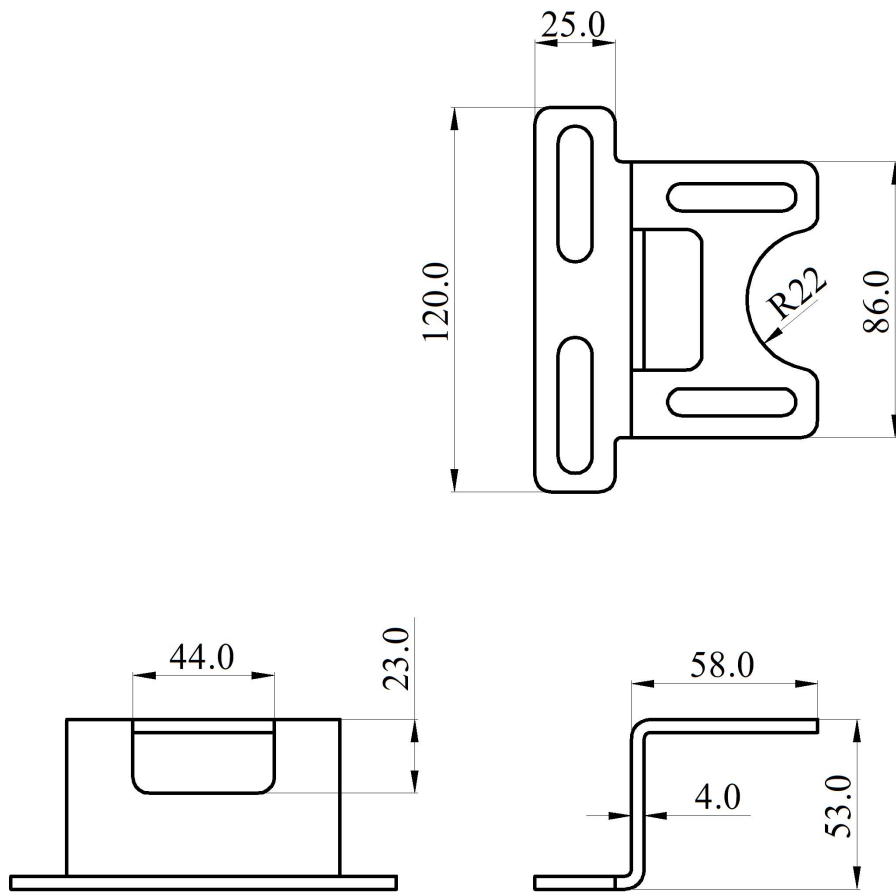

图 5. 角行程安装支架 B 型

6.3. 磁体配件尺寸

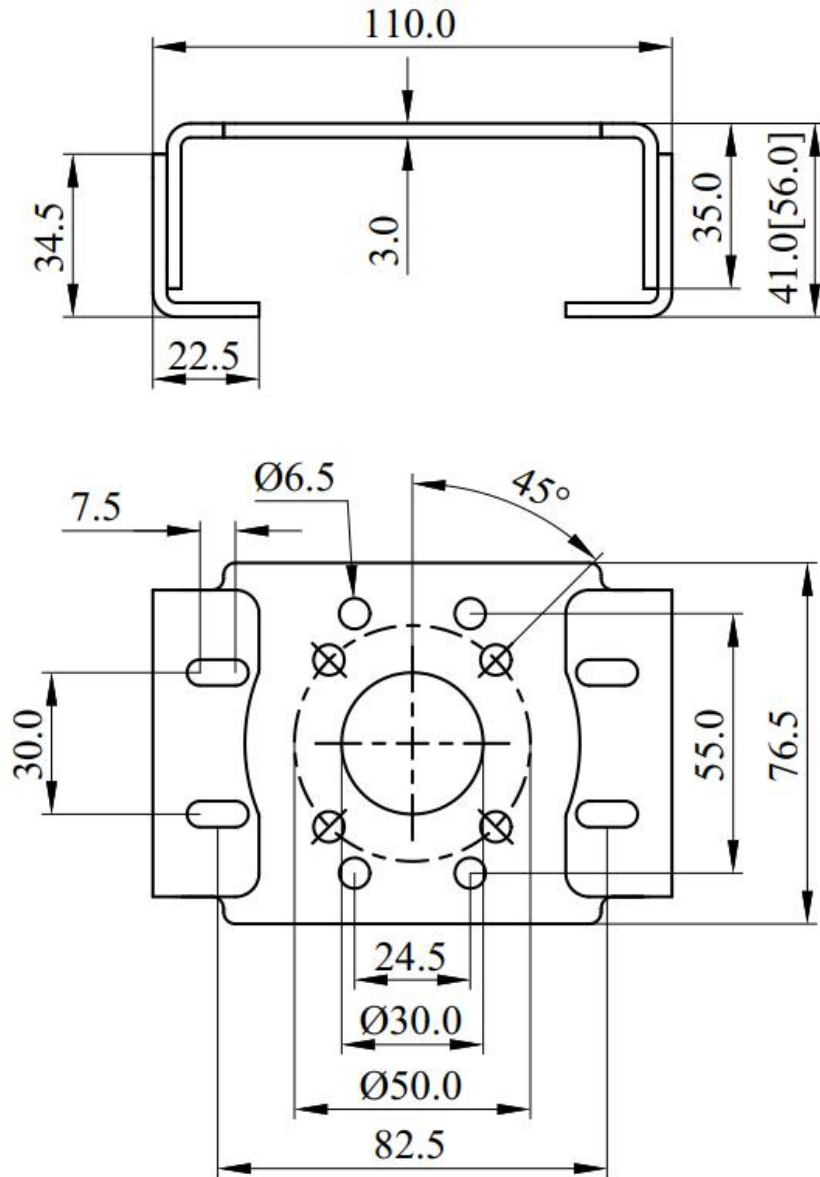

图 6. 25mm 磁条 (可用于行程 10-25mm)

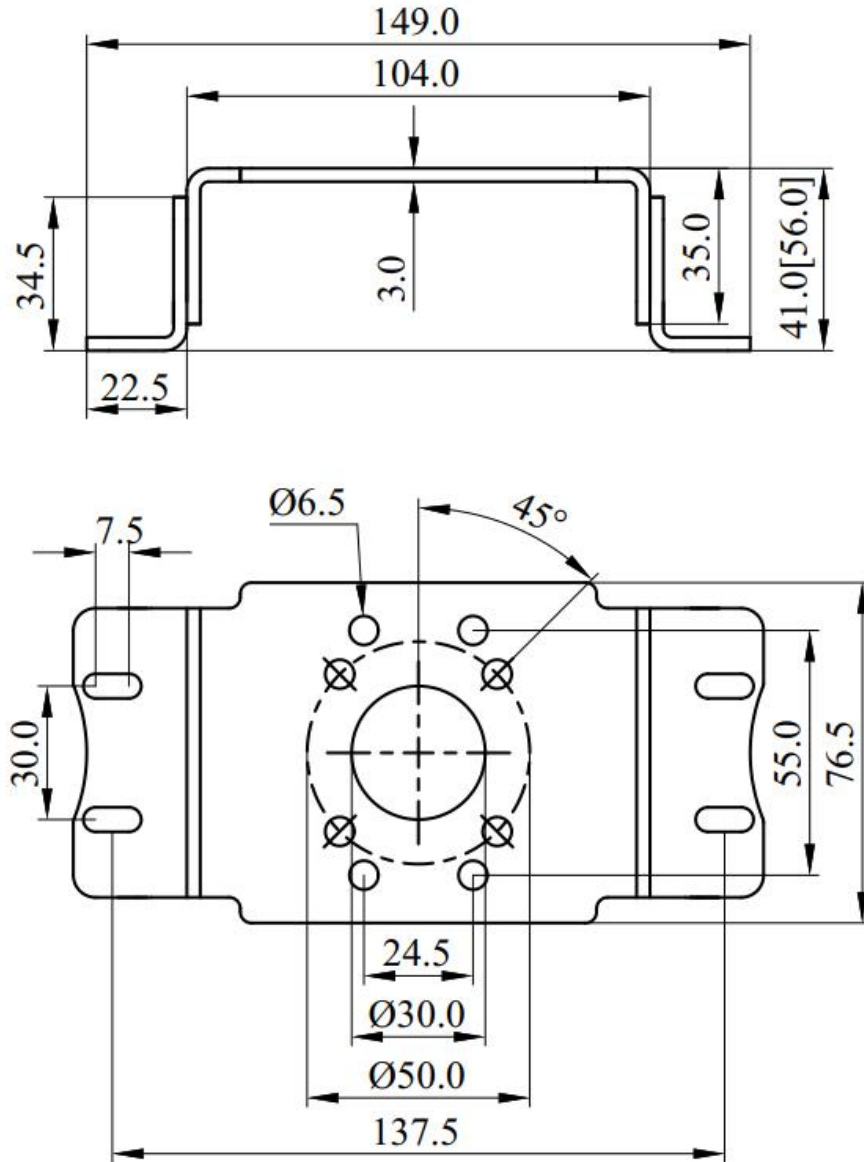

图 7. 38mm 磁条 (可用于行程 25-38mm)

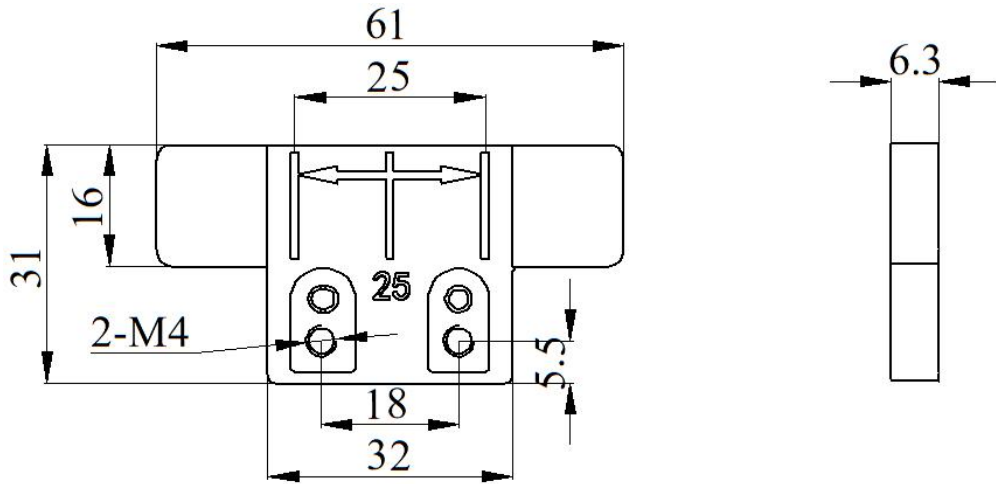

图 8. 50mm 磁条 (可用于行程 38-50mm)

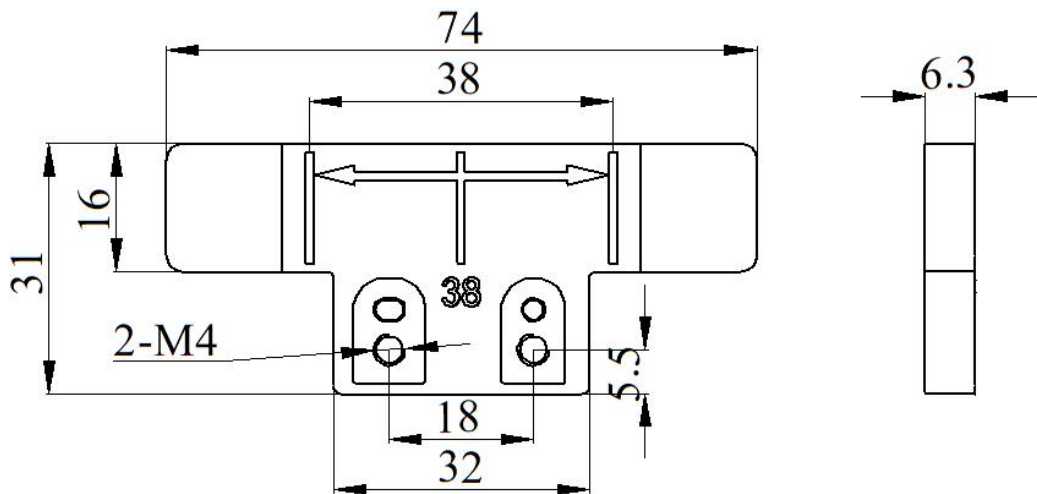

图 9. 110mm 磁条 (可用于行程 50-110mm)

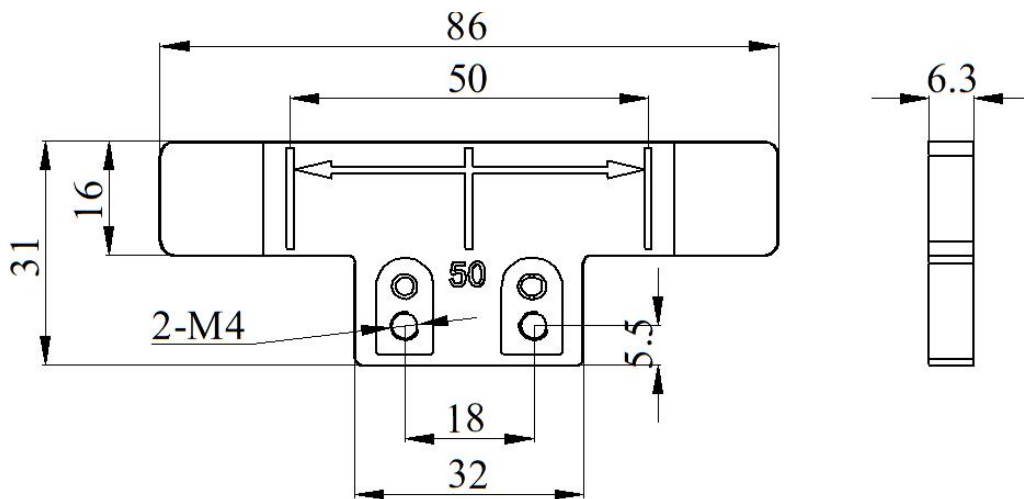

图 10. 角行程磁条外形图

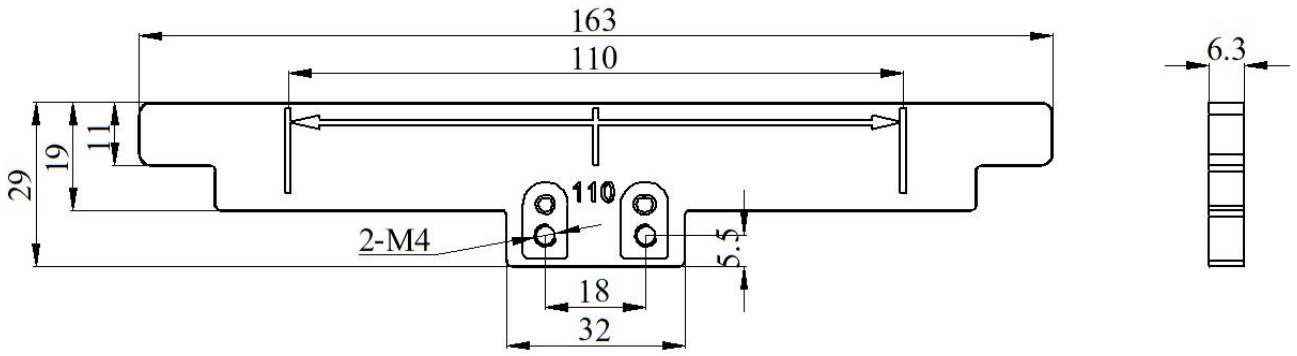

图 11. 角行程磁条连接件

7. 安装

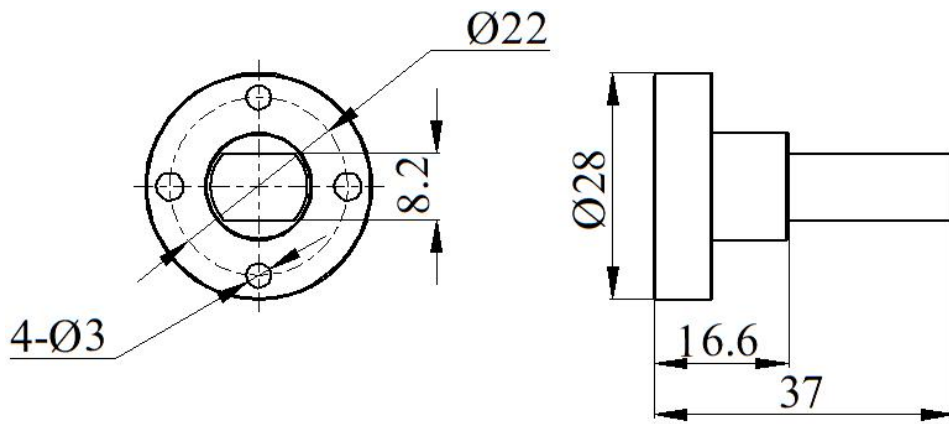
7.1. 直行程

直行程执行机构安装组件			
序号	名称	数量	注意
①	非接触式磁条	1	根据阀门行程选择特定磁条
②	磁条安装支架	1	调节并固定磁条位置
③	M6 内六角螺钉	2	M6×10 固定磁条安装支架
④	M6 弹簧垫圈	2	防止螺钉松动
⑤	M4 十字螺钉	2	M4×10 固定磁条
⑥	M4 弹簧垫圈	2	防止磁条松动
⑦	直行程安装支架	1	连接定位器与执行器
⑧	M8 六角头螺栓	2	M8×10 固定定位器
⑨	M8 弹簧垫圈	2	防止螺栓松动
⑩	M8 平垫圈	2	保护接触平面

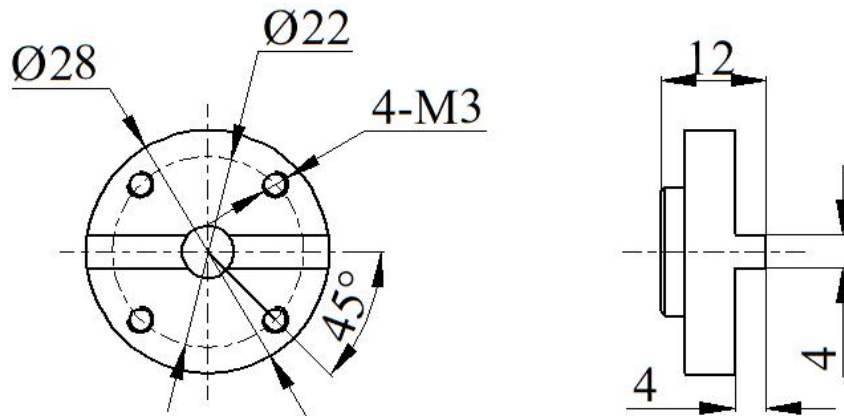
1. 将磁条安装支架安装于阀杆上，并将对应行程的磁条预拧紧在支架上。若阀杆上无安装孔，可在阀杆位置加装叉板用于辅助安装。将直行程安装支架安装至阀门上。



图 12. 直行程安装支架及磁条支架安装

2. 将定位器固定到安装支架上，调整定位器与磁条的左右相对位置。要求磁条到滑槽两侧距离相同如下图所示。磁条埋入滑槽内深度要求在 10mm~15mm 之间。

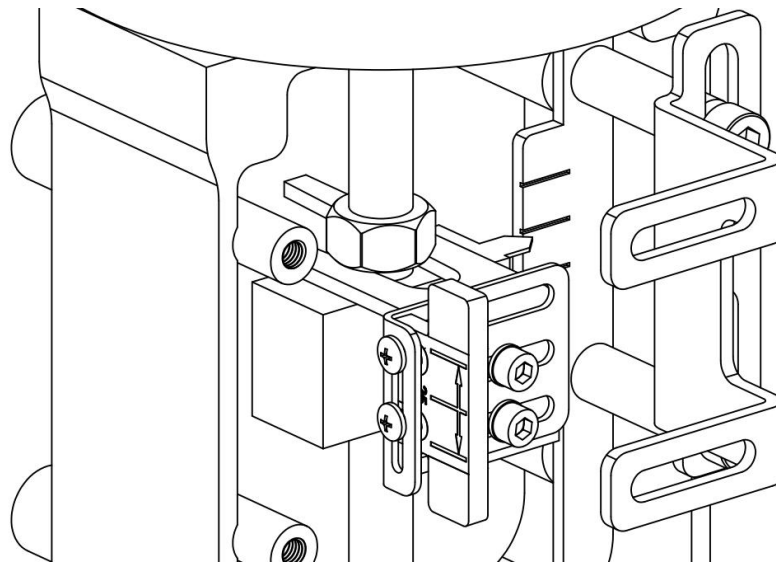

图 13. 定位器与直行程执行机构安装

3. 调整磁条相对定位器的上下方向位置。直接向执行器气缸通气使阀门开度到达 50% 的位置。此时调节磁条位置，使磁条中心也处于定位器背面滑槽中心位置。且要求磁条相对阀杆平行安装。



图 14. 阀门气缸直接通气开度到达 50%

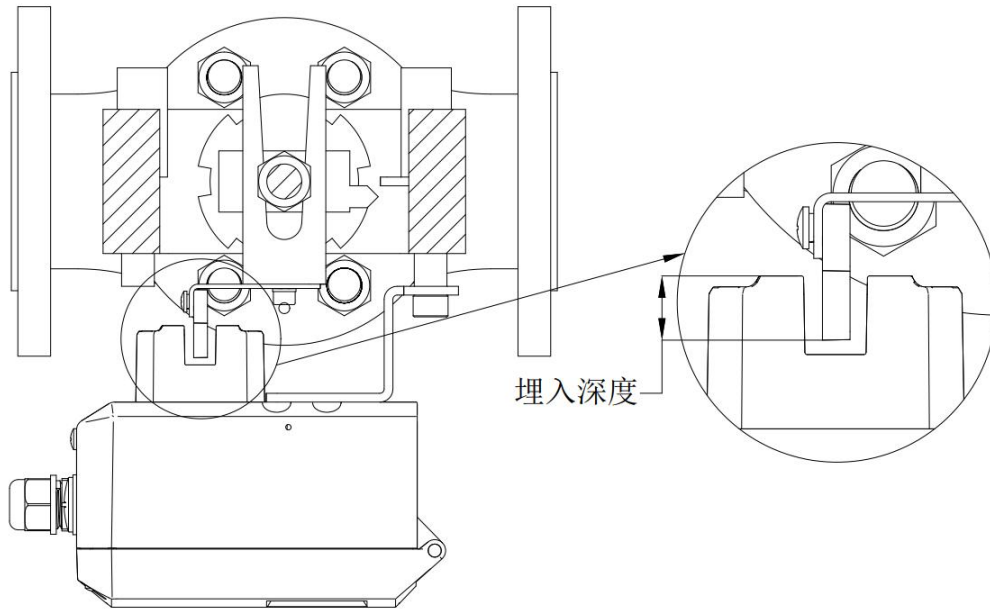

图 15. 调节磁条位置至中心线与滑槽中心线对齐

7.2. 角行程

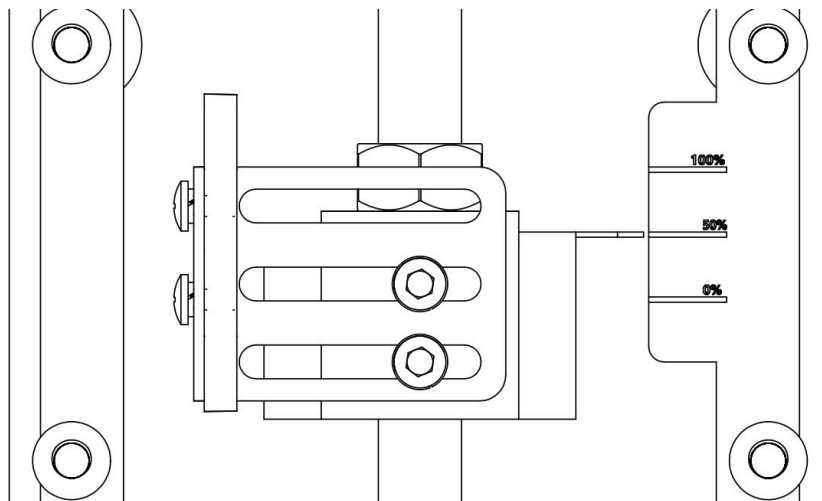
角行程执行机构安装组件			
序号	名称	数量	注意
①	角行程连接件	1	连接磁条和执行器
②	角行程磁条	1	适配 80°-100°的执行器
③	角行程安装支架	1	可兼容不同规格的执行器
④	M6 平垫圈	4	保护接触表面
⑤	M6 弹簧垫圈	4	防止螺钉松动
⑥	M6 内六角螺钉	5	M6×10 固定定位器、角行程连接件
⑦	M5 内六角螺钉	4	M5×8 固定安装支架
⑧	M5 弹簧垫圈	4	防止螺钉松动
⑨	M5 平垫圈	4	保护接触表面
⑩	M4 十字螺钉	4	M4×10 固定磁条

1. 将角行程连接件固定在执行器上。将连接件插入执行器轴的插槽内，并用内六角螺丝拧紧。保证在阀门运动过程中，连接件和阀门不会产生相对旋转。

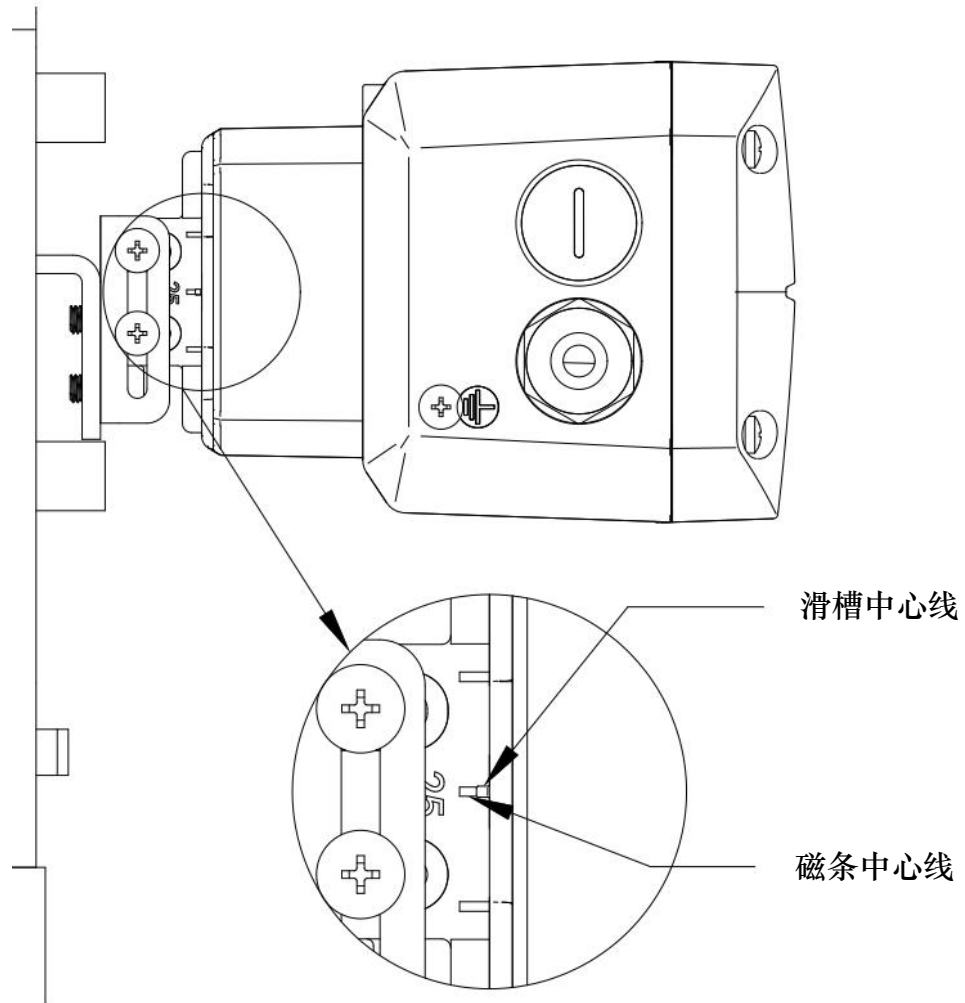

图 16. 安装角行程连接件

2. 将角行程磁条如示意图方向安装。要求磁条侧面两平面应与即将安装的定位器槽边呈 45° 。注意不同旋转方向阀门的磁条初始安装方向不同，要求开度在 50% 时，警示标签方向朝左。

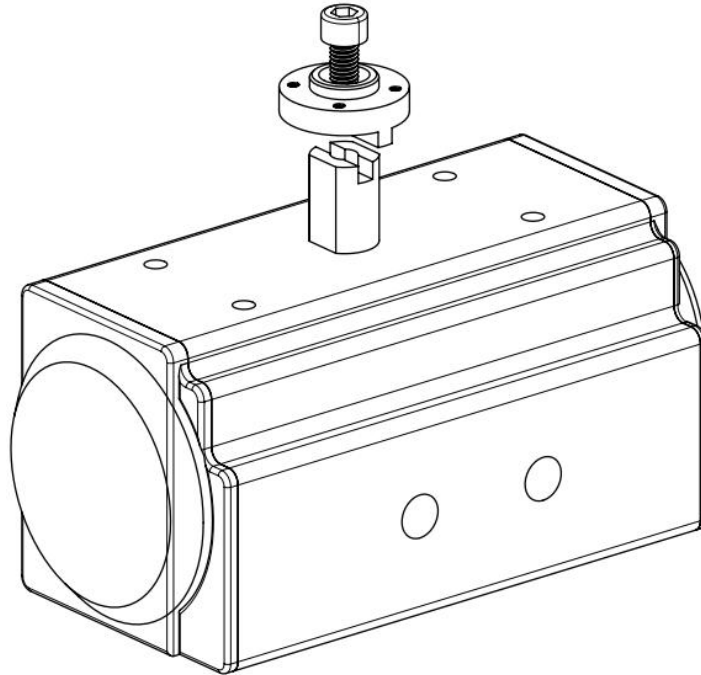

图 17. 阀门初始位置安装角行程磁条

3. 将角行程安装支架、定位器和执行器如图示进行安装固定。

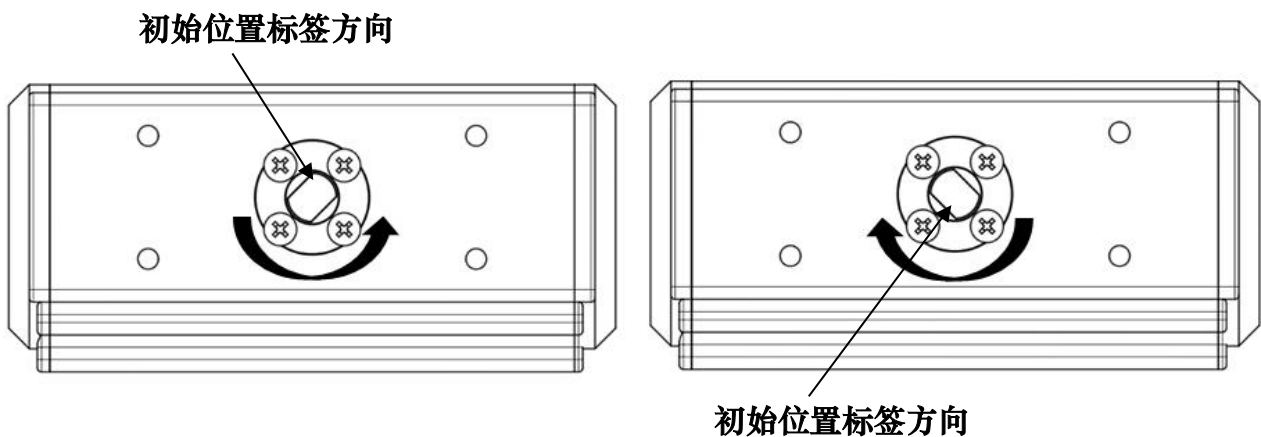

图 18. 角行程安装支架安装

4. 通过安装支架两侧的固定螺丝调节支架的高度。要求磁条在定位器背面滑槽中心位置，且磁条埋入深度在 10mm~15mm 之间。

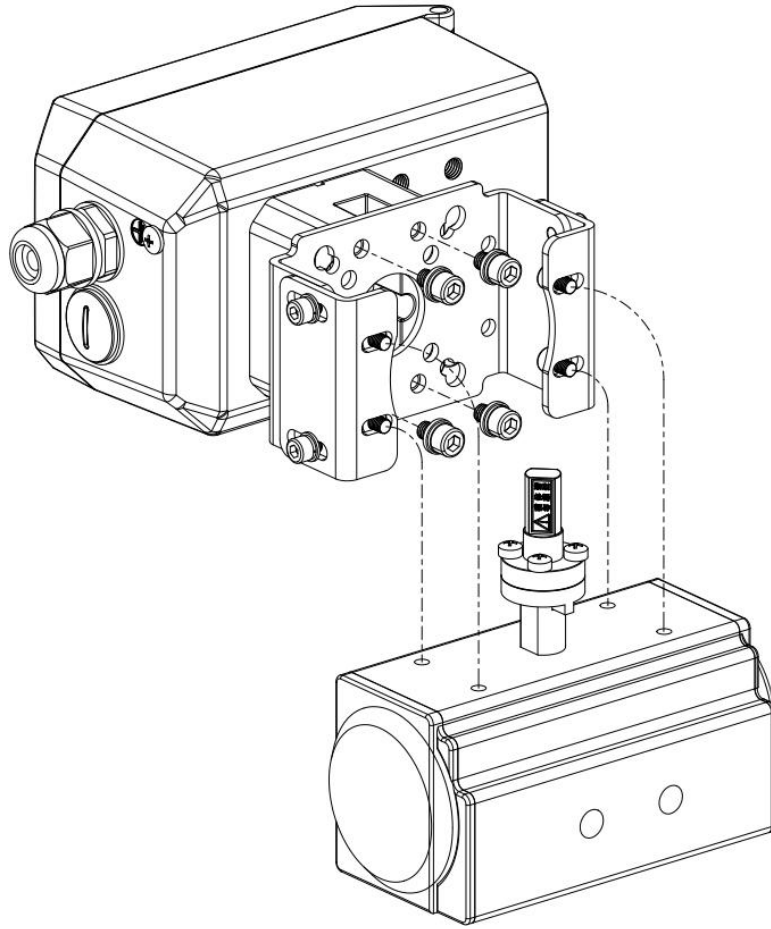

图 19. 调节安装支架高度

7.3. 安装注意事项

- 请勿将定位器安装在高磁性设备附近!
- 磁体组件材料经过专门挑选，可提供长期稳定的磁场。不过，与任何磁体一样，在处理磁体组件时必须小心谨慎。在设备临近区域（间距小于 25 mm）放置其他高磁性磁体，可能会导致设备永久性损坏。可能会损坏设备的物品包括但不限于：变压器、直流电机、叠层磁体组件。
- 请勿在磁条附近放置磁性头螺丝刀等带磁物件，这些物件可能会影响阀门控制。

7.4. 位置反馈模块

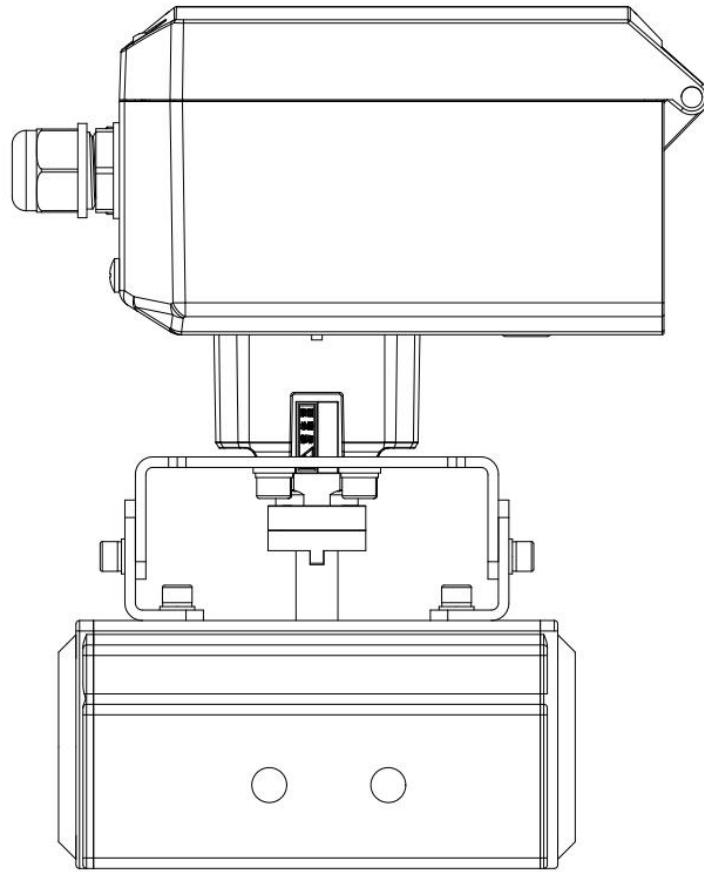
如有需要，选型时可增加反馈模块。



图 20. 反馈模块

反馈模块安装方法如下：

- 打开产品上盖，取下电路板保护盖。

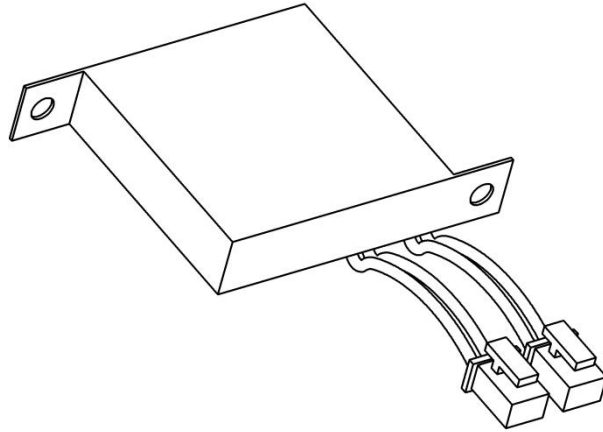

图 21. 拆除电路板保护盖

- 将反馈模块按图示位置安装，模块电气接口和电路板上接口按照对应颜色连接，用 M3 弹垫和 M3 盘头螺钉固定反馈模块，最后装上电路板保护盖。

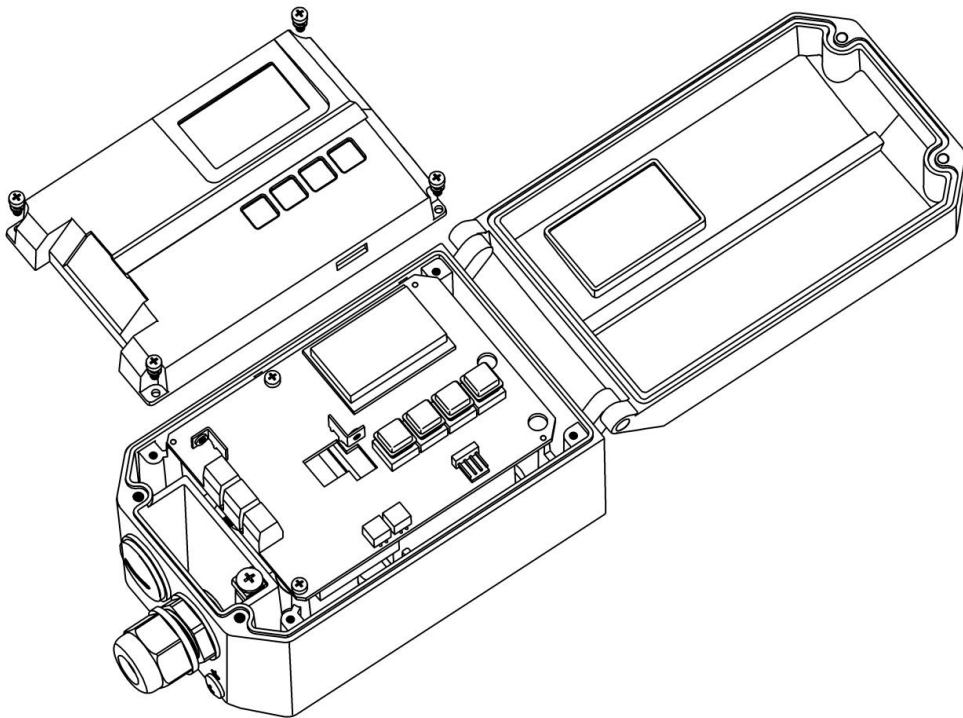

图 22.反馈模块安装

注意：请在设备断电情况下拆装电路板保护盖。

8. 操作



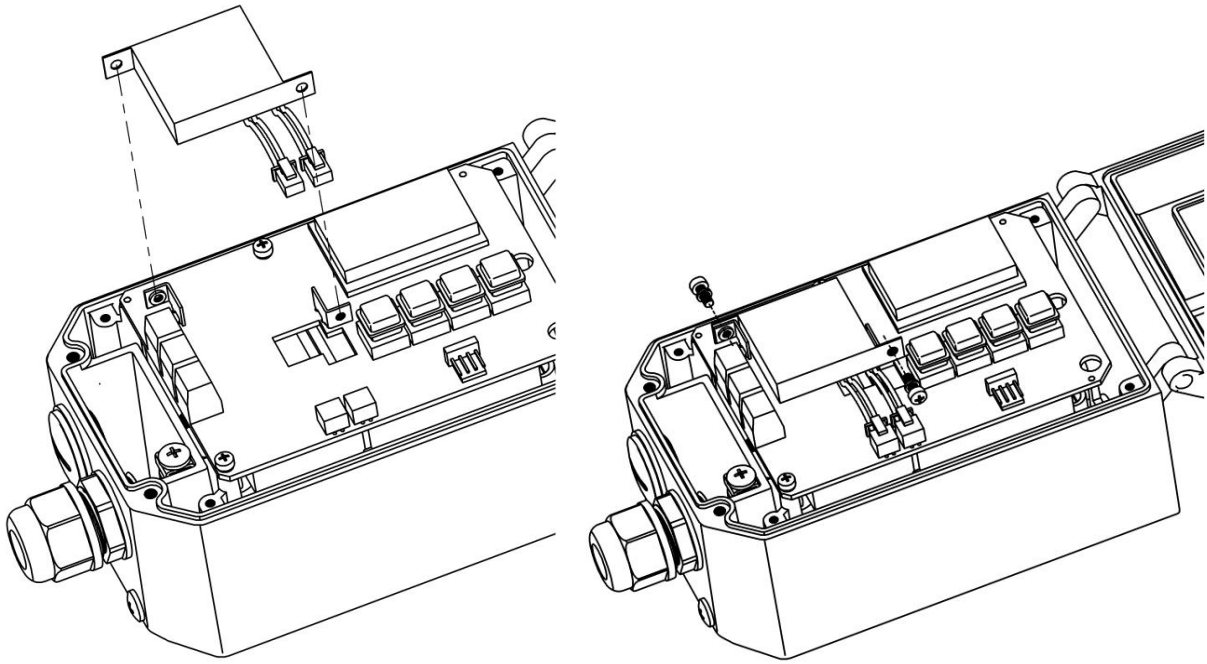



8.1. 界面描述

用户操作界面由一个 LCD 和 4 个按键组成。

LCD 显示说明

位置	描述
第一行	<ul style="list-style-type: none"> ● 初始界面 (NOINI) 或运行初始化功能时显示角度传感器百分比值。 ● 工作模式下显示阀位百分比值。 ● 菜单模式下显示参数值。
第二行	<ul style="list-style-type: none"> ● 未初始化状态下显示提示标志。 ● 工作模式下显示自动或手动模式。 ● 工作模式下设定百分比值。 ● 菜单模式下显示功能选项。 ● 初始化过程中显示初始化进程和错误提示。

按键操作说明

按键	操作说明
	<ul style="list-style-type: none"> ● 进入系统菜单。 ● 工作模式下手自动模式切换。 ● 从系统菜单退出到主界面。 ● 从子菜单退出到上一级菜单。
	<ul style="list-style-type: none"> ● 初始界面 (NOINI) 下打开或关闭阀门。 ● 手动模式下减小阀位值。如果先按住此键，再按住键，阀位值快速减少。 ● 菜单模式下向下选择功能选项、参数或减小数值参数值。
	<ul style="list-style-type: none"> ● 初始界面 (NOINI) 下打开或关闭阀门。 ● 手动模式下增加阀位值。如果先按住此键，再按住键，阀位值快速增加。 ● 菜单模式下向上选择功能选项、参数或增加数值参数值。
	<ul style="list-style-type: none"> ● 菜单模式下进入子菜单、使能或确认参数修改。 ● 菜单模式下运行初始化或恢复出厂设置。 ● 初始界面 (NOINI) 或手自动模式界面运行初始化功能。

8.2. 主界面显示和操作

系统在没完成初始化功能前处于未初始化状态。显示标志为 NOINI，界面第一行显示传感器百分比值。



图 23. 未初始化状态界面

在此状态下，操作 \downarrow/\uparrow 键可打开或关闭阀门。将阀门全开和全闭，观察界面上显示传感器百分比值。确保在整个阀门行程范围内，传感器百分比值单调变化。否则，需要重新调整安装位置。另外，要求传感器最小最大百分比差值大于 15%。

如果要快捷操作自动初始化 (INITA) 功能，则在初始界面 (NOINI) 或手自动模式界面长按 \odot 键 3 秒左右开始运行自动初始化。初始化运行过程中按 \rightarrow 键可退出。退出后，如果之前初始化完成过，则进入手动模式界面，否则进入初始界面 (NOINI)。初始化完成后，按 \rightarrow 键退出。退出后，系统进入手动模式界面。

系统工作模式分为自动模式和手动模式。

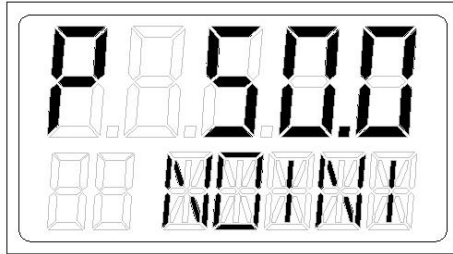
在自动模式下，系统采集外部 4-20mA 设定信号自动调节阀门开度。

在手动模式下，通过手动操作 \downarrow/\uparrow 键来调节阀门开度。

主界面上第一行显示阀位百分比值，第二行显示设定百分比值。其中第二行设定百分比显示值最后一个数值为一位小数。符号 A 表示自动模式，符号 M 表示手动模式。可通过按键 \rightarrow 切换自动模式和手动模式。键按住后松开时间小于进入菜单操作的时间则进行手自动模式切换，否则进入菜单。







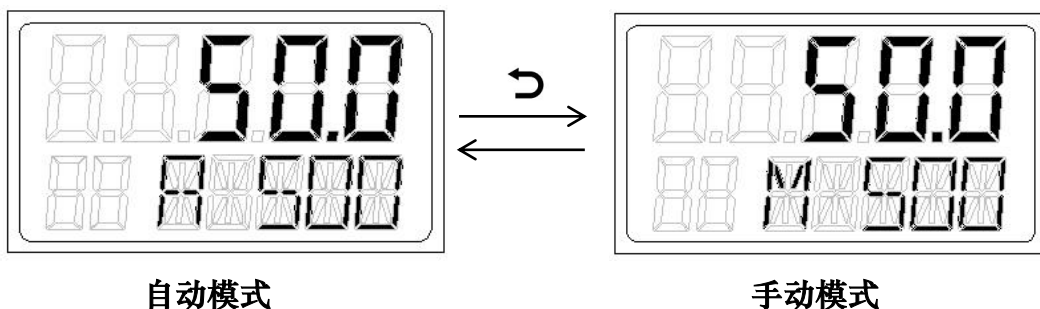

图 24. 系统工作模式界面

在自动模式下可执行 PST 功能（部分行程测试）。长按  键 3 秒左右切换到 PST 操作界面。按  键可退出到自动模式界面。在 PST 操作界面，如果 PST 功能未开启，则界面上第一行显示 **oFF**。如果 PST 功能已开启，当阀位和起始位置的差值绝对值在起始位置容差范围内且 PST 参数配置无误，则在 PST 操作界面长按  键 3 秒左右执行 PST 功能。执行机构按照设置的 PST 参数从起始位置移动到目标位置上限或下限。如果 PST 功能执行成功，则显示 **SUCS**。如果 PST 功能执行失败，则显示 **FAIL**。执行 PST 功能时，可按  键中断执行。如果不满足 PST 功能执行条件，则提示如下错误代码。

错误代码	描述
Err 1	阀位和起始位置的差值绝对值不在起始位置容差范围内。
Err 2	PST 参数配置错误。必须满足目标位置上限 $\leq 99\%$ ，目标位置下限 $\geq 1\%$ 。

8.3. 菜单和功能

8.3.1. 菜单显示和操作

长按  键 3 秒左右，系统进入菜单。在菜单界面，按  键，系统从菜单界面退出到手动模式工作界面。带 HART 功能的定位器在菜单界面下无法通过 HART 通讯来修改参数或运行初始化操作。



图 25. 菜单界面



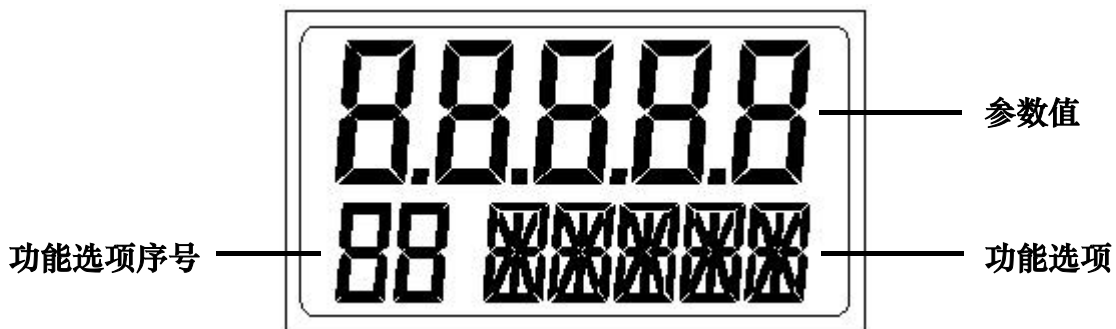

8.3.2. 功能描述和操作

8.3.2.1. TYPE

选择执行机构类型。

设置参数选项

选项	描述
Lin	直行程执行机构。
Turn	角行程执行机构。

菜单界面选择此功能，按  键开启参数设置，参数闪烁显示。按  键设置参数。按  键确认修改。

8.3.2.2. INITA

该功能为自动初始化。该功能自动检测动作方向，阀门实际物理行程，控制参数。







菜单界面选择此功能，长按  键 3 秒左右开始运行，LCD 左下角出现滚动标志，第一行显示传感器百分比值，第二行显示运行步骤。自动初始化完成后，LCD 上显示 FINSH。

自动初始化过程中由于某些原因，系统会在功能选项栏显示错误提示。并中断初始化。错误提示说明及处理方法详见 8.3.3 章节。

8.3.2.3. INITM

该功能为手动初始化。适用于用户手动来确定阀门行程。

该功能先手动标定阀门行程，再自动检测动作方向，控制参数。操作流程如下：

1. 菜单界面选择此功能，长按  键3秒左右开始运行，LCD左下角出现滚动标志，第一行显示传感器百分比值，第二行显示显示END 1。
2. LCD上显示END 1后，操作  键将阀位移动至手动标定的行程端点1，按  键确认，LCD上显示END 2。再次操作  键将阀位移动至手动标定的行程端点2，按  键确认。
3. END 2确认后，如果LCD上没有错误提示，则系统自动从初始化第1步开始执行，并跳过第2步行程检测。





手动初始化完成后，LCD上显示FINSH。

手动初始化过程中由于某些原因，系统会在功能选项栏显示错误提示。并中断初始化。错误提示说明及处理方法详见8.3.3章节。

8.3.2.4. CAL

4-20mA 设定信号的校正。当设定值与信号源的输出值有较大偏差时，可通过此功能对设定信号做校正。



CAL 的子功能选项 4 mA 和 20 mA 分别校正 4-20mA 设定信号最小最大值。

菜单中选择此功能，按  键进入子功能选择操作，按  键选择子功能选项 **4 mA** 或 **20 mA**，按  键开启参数设置，LCD 上闪烁显示实际设定信号的 **AD 值**（将设定信号用数字来量化，范围为 0-4095 的数值）。对于选项 **4 mA**，将前端设定信号设置为 4 mA 信号；对于选项 **20 mA**，将前端设定信号设置为 20 mA 信号。例如，前端设定信号设置为 4 mA 时，LCD 上闪烁显示数值为 650，待 LCD 上 AD 值稳定后按  键确认，系统会记录当前 AD 值 (650) 并显示在 LCD 上；例如，前端设定信号设置为 20 mA 时，LCD 上闪烁显示数值为 3270，待 LCD 上 AD 值稳定后按  键确认，系统会记录当前 AD 值(3270)并显示在 LCD 上。选项 **4 mA** 和选项 **20 mA** 都操作完成后即完成 4-20mA 设定信号的校正。

例如现场 4-20mA 信号设定为 50%(12mA)，而定位器实际采集的信号值 52%(12.32 mA)。说明设定信号和定位器实际采集的信号存在偏差。此时通过如上所述的菜单操作来校正定位器采集的设定值，使其与系统前端 4-20mA 信号设定值对应。

8.3.2.5. SDIR

此功能用来设置 4-20mA 设定信号与设定值之间的对应关系。

菜单界面选择此功能，按  键开启参数设置，参数闪烁显示。按  键设置参数。按  键确认修改。

设置参数选项

选项	描述
riSE	4 mA → 0%，20 mA → 100%。
FALL	4 mA → 100%，20 mA → 0%。



图 26.SDIR

8.3.2.6. CHAR

特性曲线是阀位设定值与阀门行程的转换关系。

在实际控制系统中，通常要求使被控量具有特定的控制特性（比如线性）。用户可以选择

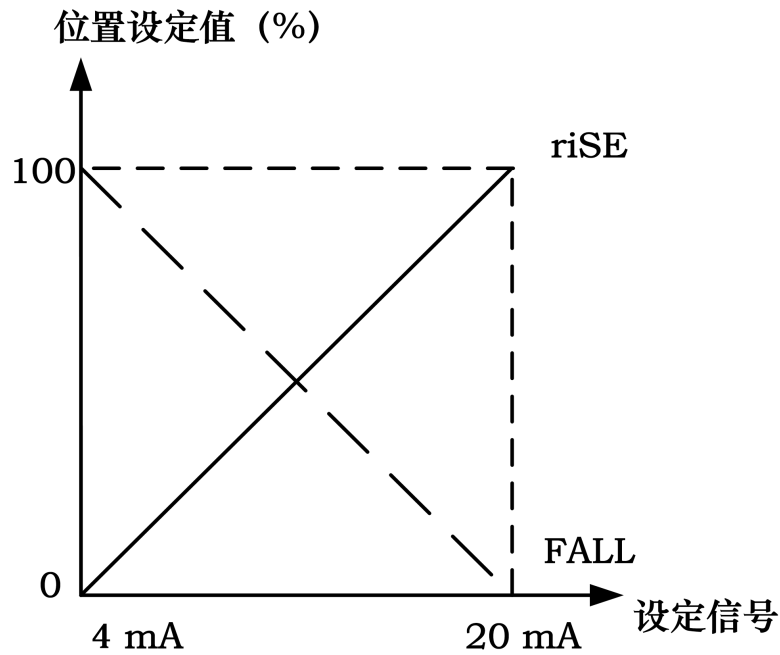
和设置相应的特性曲线来达到控制要求。

菜单界面选择此功能，按 键开启参数设置，参数闪烁显示。按 键设置参数。按 键确认修改。

特性曲线参数选项

选项	描述
Lin	位置设定值与阀门行程为 1:1 转换关系。
1-25	位置设定值与阀门行程为 1:25 等百分比转换关系。
1-33	位置设定值与阀门行程为 1:33 等百分比转换关系。
1-50	位置设定值与阀门行程为 1:50 等百分比转换关系。
n1-25	位置设定值与阀门行程为 1:25 反等百分比转换关系。
n1-33	位置设定值与阀门行程为 1:33 反等百分比转换关系。
n1-50	位置设定值与阀门行程为 1:50 反等百分比转换关系。
FrEE	用户自定义位置设定值与阀门行程的转换关系。将 0-100% 的设定值范围等间隔分为 21 个设定点。每个点上都可设置行程范围为 0-100% 的值。可在 FR 0,

FR 5, ..., FR 100 选项中设置数值。



图 27.CHAR

8.3.2.7. FREE

设置 CHAR 功能选项中 FrEE 特性曲线的数值。

FREE 的子功能选项为 FR 0, FR 5, ..., FR100, 共 21 个设定点。

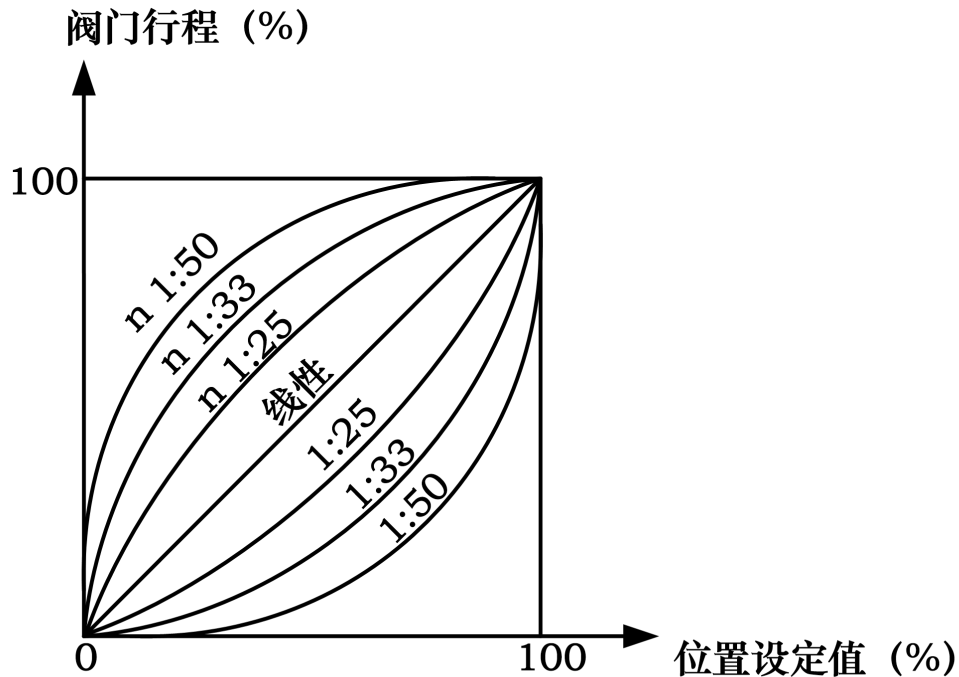
菜单中选择此功能, 按 键进入子功能选择操作, 按 键选择设定点, 按 键开启参数设置, 参数闪烁显示。按 键设置参数, 持续按 键或 键可快速修改参数。按 键确认修改。



图 28.FREE

8.3.2.8. DB

定位器死区设置。

阀位值与阀位设定值之间的差值在死区设置范围内时，系统认为调节到位而不做位置调节动作。

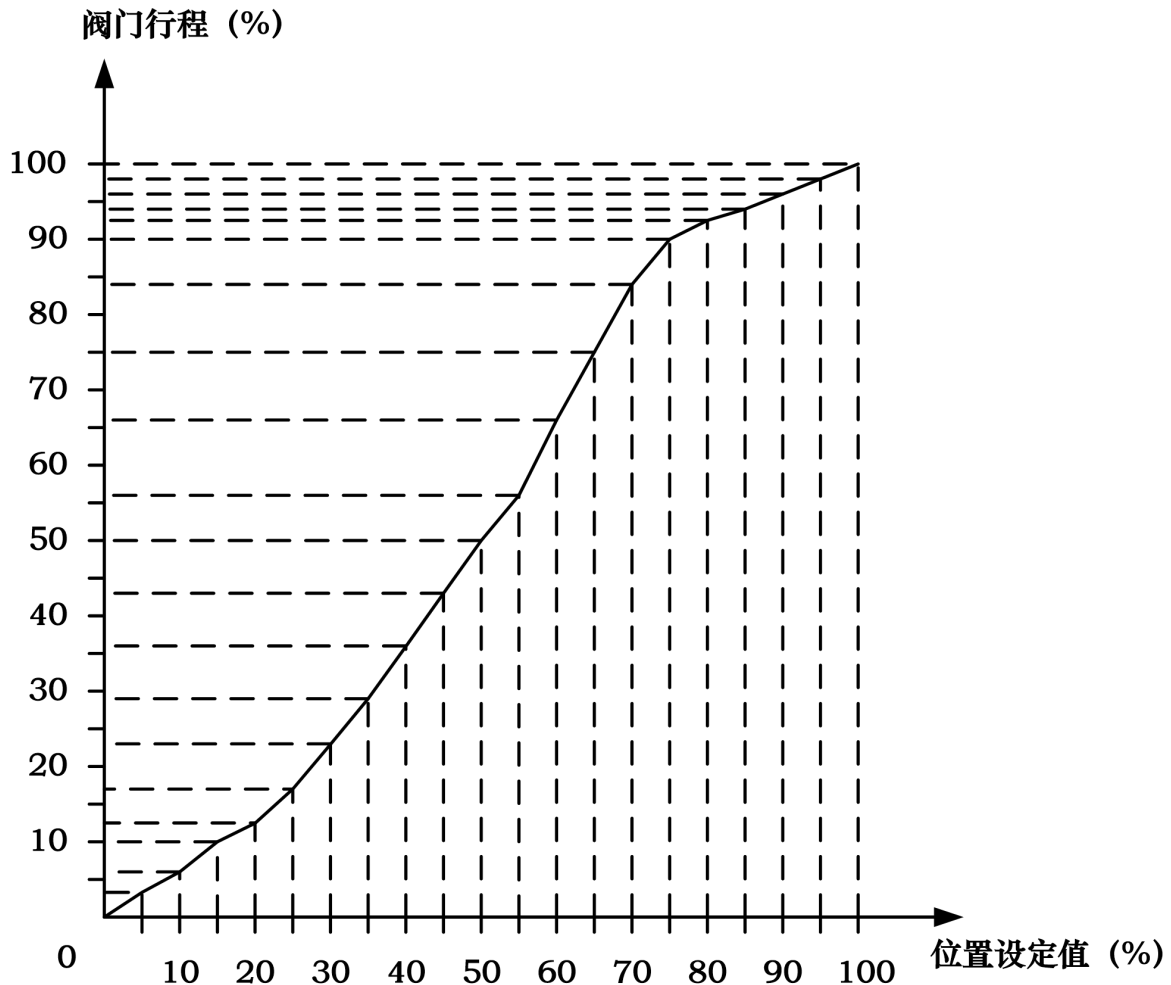
例如，阀位设定值为 50%，死区值为 1%。则实际阀位在 $50 \pm 1\%$ 范围内不做调节动作。如果实际阀位不在 $50 \pm 1\%$ 范围内，则驱动压电模块调节阀位，最终使阀位处于 $50 \pm 1\%$ 范围内。

如果阀位震荡，可将死区调大抑制震荡。死区越小，控制精度就越高。

菜单中选择此功能，按 键开启参数设置，参数闪烁显示。按 键设置参数，持续按 键或 键可快速修改参数。按 键确认修改。

8.3.2.9. LIM

此功能用于限制阀门在物理行程范围内的调节范围。

LIM 的子功能选项 L MIN 和 L MAX 分别设置限制行程的最小最大值。

菜单中选择此功能,按 \odot 键进入子功能选择操作,按 ∇/\blacktriangle 键选择子功能选项 L MIN 或 L MAX,按 \odot 键开启参数设置,参数闪烁显示。按 ∇/\blacktriangle 键设置参数,持续按 ∇ 键或 \blacktriangle 键可快速修改参数。按 \odot 键确认修改。



图 29.LIM

8.3.2.10.YDIR

此功能用于设置设定值显示、位置显示以及位置反馈信号输出的动作方向。

菜单界面选择此功能,按 \odot 键开启参数设置,参数闪烁显示。按 ∇/\blacktriangle 键设置参数。按 \odot 键确认修改。

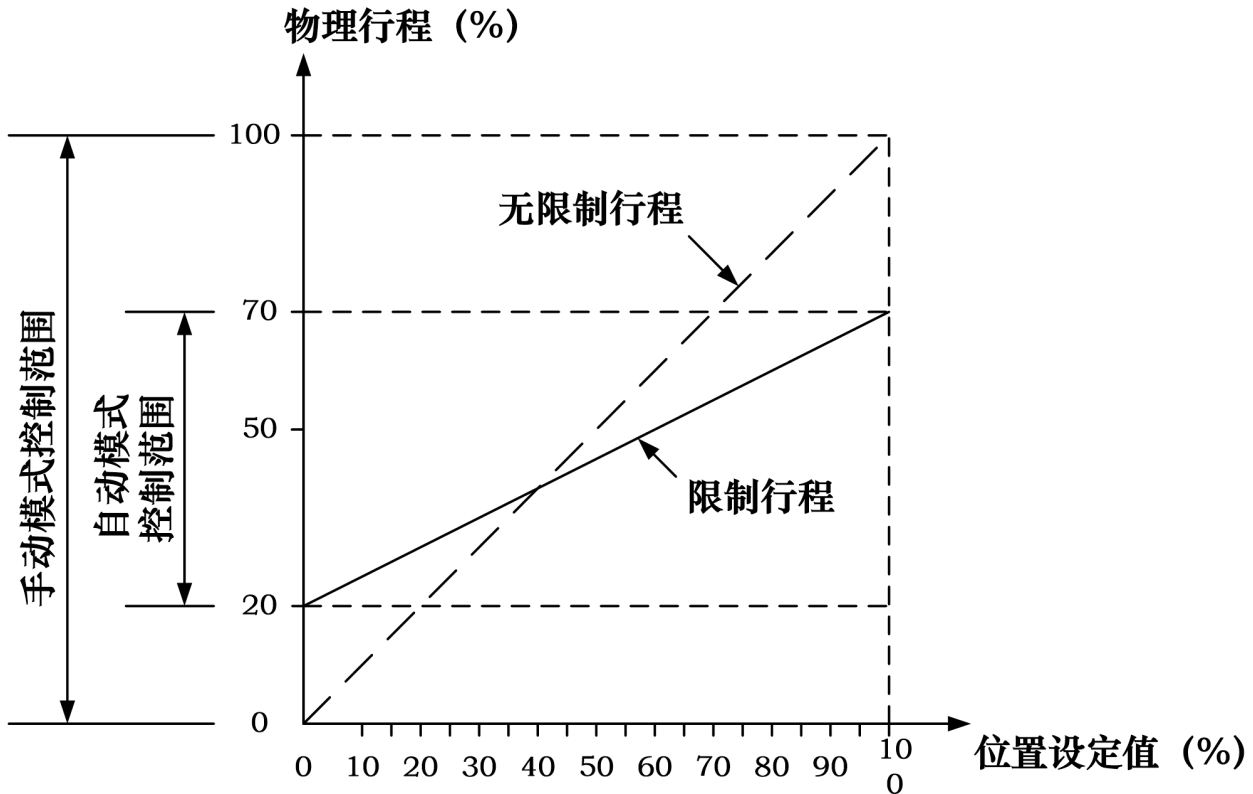
设置参数选项

选项	描述
riSE	设定值显示、位置值显示以及位置反馈信号输出为上升趋势。
FALL	设定值显示、位置值显示以及位置反馈信号输出为下降趋势。

8.3.2.11.CUT

此功能用于定位器在自动模式下使阀门完全关闭或完全打开。当紧闭功能使能后,主界

面左下角显示 CU 标志。

CUT 的子功能选项 C MIN 和 C MAX 分别设置紧闭最小最大值。

菜单中选择此功能,按 \odot 键进入子功能选择操作,按 ∇/\blacktriangle 键选择子功能选项 C MIN 或 C MAX,按 \odot 键开启参数设置,参数闪烁显示。按 ∇/\blacktriangle 键设置参数,持续按 ∇ 键或 \blacktriangle 键可快速修改参数。按 \odot 键确认修改。

当 C MIN 为 0 时,完全关闭不起作用。当 C MAX 为 100 时,完全打开不起作用。

在阀门定位状态,当设定值 \leq C MIN 时,阀门完全关闭;当设定值 \geq C MAX 时,阀门完全打开。

在完全关闭状态,当设定值 $>$ C MIN + 1% 时,阀门脱离完全关闭状态。

在完全打开状态,当设定值 $<$ C MAX - 1% 时,阀门脱离完全打开状态。





图 30.CUT

8.3.2.12.POS

此功能用于设置位置显示和反馈信号输出的标准。

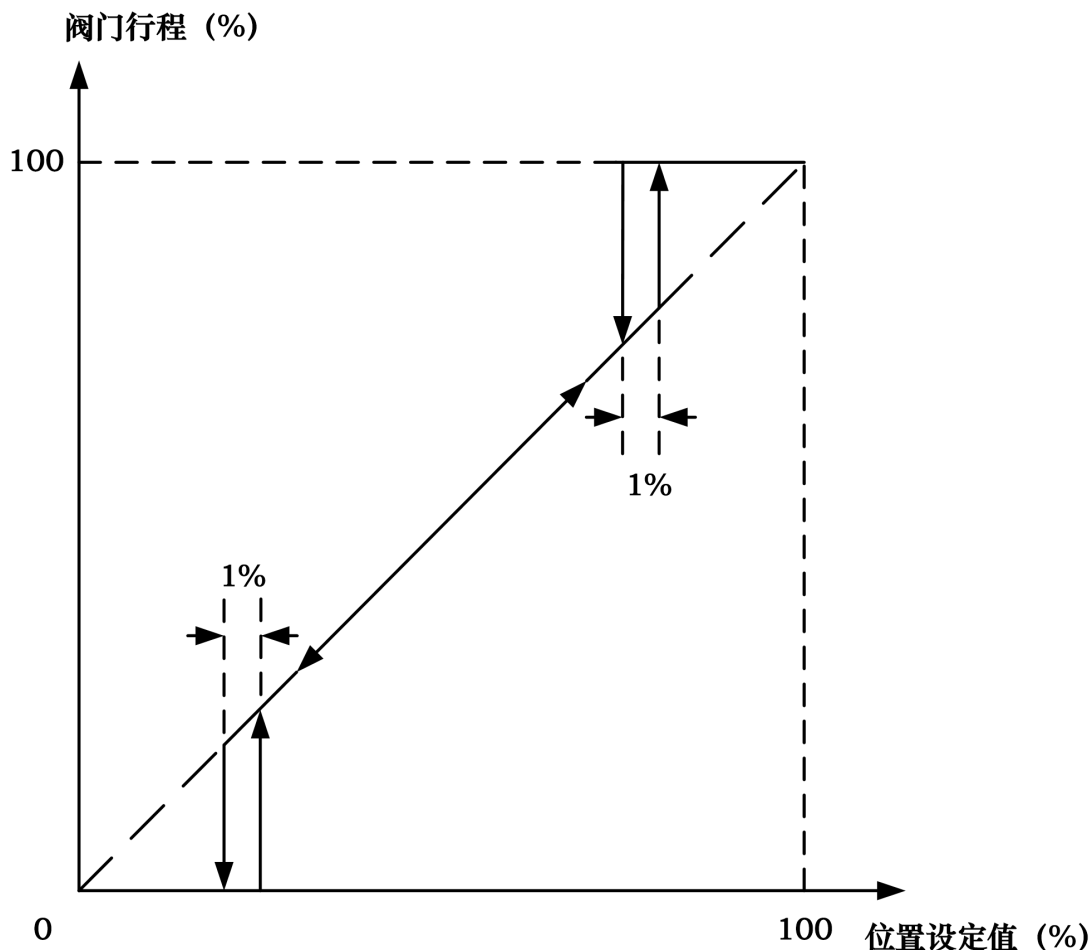
菜单界面选择此功能,按 \odot 键开启参数设置,参数闪烁显示。按 ∇/\blacktriangle 键设置参数。

按  键确认修改。

设置参数选项

选项	描述
FS	位置显示和反馈信号输出对应机械行程 0-100%。设定值以实际阀位设定值显示。不受 L MIN 和 L MAX 参数影响。
LS	位置显示和反馈信号输出采用 0-100%的形式来表示 L MIN 和 L MAX 参数之间的范围。设定值以此标准显示。



图 31. 示例: POS = FS, L MIN = 20%, L MAX = 90%





图 32. 示例: POS = LS, L MIN = 20%, L MAX = 90%

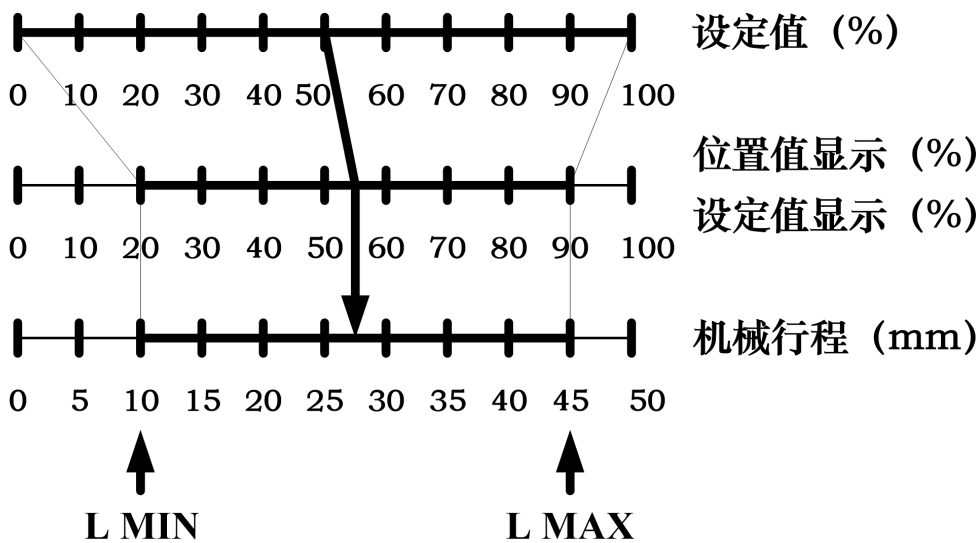

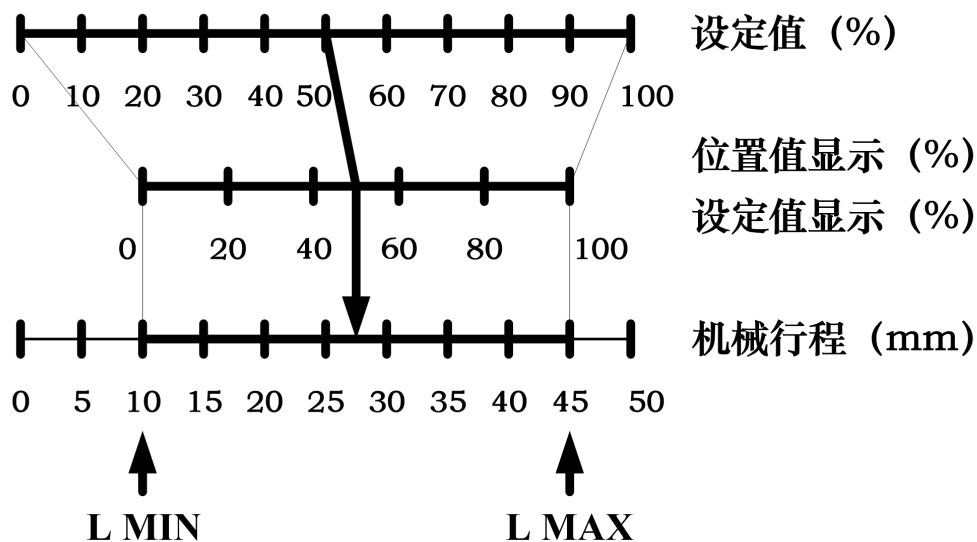

8.3.2.13.FACT

将定位器恢复到出厂设置。

菜单中选择此功能，长按  键 3 秒左右恢复出厂设置。恢复出厂设置后，系统处于未初始化状态，LCD 显示 FINSH。

8.3.2.14.WP

此功能为参数写保护功能。参数 oFF 为写保护关闭，参数 on 为写保护开启。

菜单界面选择此功能，按  键开启参数设置，参数闪烁显示。按  键设置参数。按  键确认修改。

当写保护开启后，大部分菜单选项参数无法修改，初始化和恢复出厂设置功能无法运行。

8.3.2.15.ACT

作用方式选择。厂家内部使用。无特殊情况不建议用户操作此选项。

8.3.2.16.REC

定位器运行数据记录。参数无法通过运行 FACT 功能来恢复出厂值。

记录数据选项

选项	描述
HOURS	运行小时数。定位器上电后开始记录。
P CNT	正向偏差次数。在自动模式下，当定位器处于定位状态时，将基于初始化后的机械行程对应的位置值与位置设定值做比较。如果设定值大于位置值，且两者偏差超过死区值+10%并持续超过 1 分钟，累计计数 1 次。
N CNT	负向偏差次数。在自动模式下，当定位器处于定位状态时，将基于初始化后的机械行程对应的位置值与位置设定值做比较。如果位置值大于设定值，且两者偏差超过死区值+10%并持续超过 1 分钟，累计计数 1 次。
CLR	清空 HOURS, P CNT, N CNT 记录。REC 子菜单中选择此功能，长按  键 3 秒左右开始运行。记录清空后，LCD 上显示 FINSH。
S/W	开启或关闭数据记录。参数 oFF 为关闭，参数 on 为开启。

8.3.2.17.LCD

此功能为设置显示屏显示方向。参数 uP 为正向显示，参数 do 为反向显示。此参数无法

通过运行 FACT 功能来恢复出厂值。

对于个别直行程阀门，如果设备需要反向安装到阀门上，可设置此参数使显示屏正向显示。

菜单界面选择此功能，按 键开启参数设置，参数闪烁显示。按 键设置参数。按 键确认修改。

8.3.2.18. DIAG

诊断参数。菜单界面选择此选项，按 键进入。

8.3.2.19.1. PST

部分行程测试参数。参数 STPOS、RANGE、STEP、DIR 关联初始化后的行程。

菜单界面选择参数选项，按 键开启参数设置，参数闪烁显示。按 键设置参数。按 键确认修改。

执行 PST 功能（部分行程测试），请详见 8.2 章节。

选项	描述
S/W	开启或关闭部分行程测试功能。参数 oFF 为关闭，参数 on 为开启。
STPOS	部分行程测试的起始位置。
RANGE	起始位置的容差范围。比如，起始位置 50%，容差范围为 2%。只有当阀位在 48%~52%范围内执行部分行程测试。
STEP	步进行程。
DIR	部分行程测试的行程方向。 参数值 uP：执行机构向上移动，从起始位置移动到目标位置上限。 参数值 do：执行机构向下移动，从起始位置移动到目标位置下限。 参数值 uP do：执行机构上下移动，先从起始位置移动到目标位置上限。再从目标位置上限移动到目标位置下限。 目标位置上限 = STPOS + RANGE + STEP。 目标位置下限 = STPOS - RANGE - STEP。
TIME	部分行程测试的限制时间。单位：秒。启动部分行程测试后，当到达限制时间，执行机构还未移动到目标位置上限或下限，则认为测试失败。请根据阀门实际运行状况合理设置此值。

8.3.2.19.SPLIT

此功能用于分程控制。

SPLIT 的子功能选项 S MIN 和 S MAX 分别设置分程区间的最小最大值。设置的 S MAX 和 S MIN 的差值建议不小于 30。

菜单中选择此功能，按 \odot 键进入子功能选择操作，按 $\blacktriangledown/\blacktriangle$ 键选择子功能选项 S MIN 或 S MAX，按 \odot 键开启参数设置，参数闪烁显示。按 $\blacktriangledown/\blacktriangle$ 键设置参数，持续按 \blacktriangledown 键或 \blacktriangle 键可快速修改参数。按 \odot 键确认修改。



图 33.SPLIT

8.3.2.20.EXT

此功能用于优化显示行程端点 0% 和 100% 处的位置值。

当阀位在行程端点 0% 或 100% 处时，LCD 显示的位置值可能不为 0% 或 100%。比如在行程端点 0% 时显示 0.2%。如果用户想让位置值显示为 0%，可通过设置该功能参数。当位置值与 0% 或 100% 的差值的绝对值小于等于该参数值时，LCD 显示 0% 或 100%。

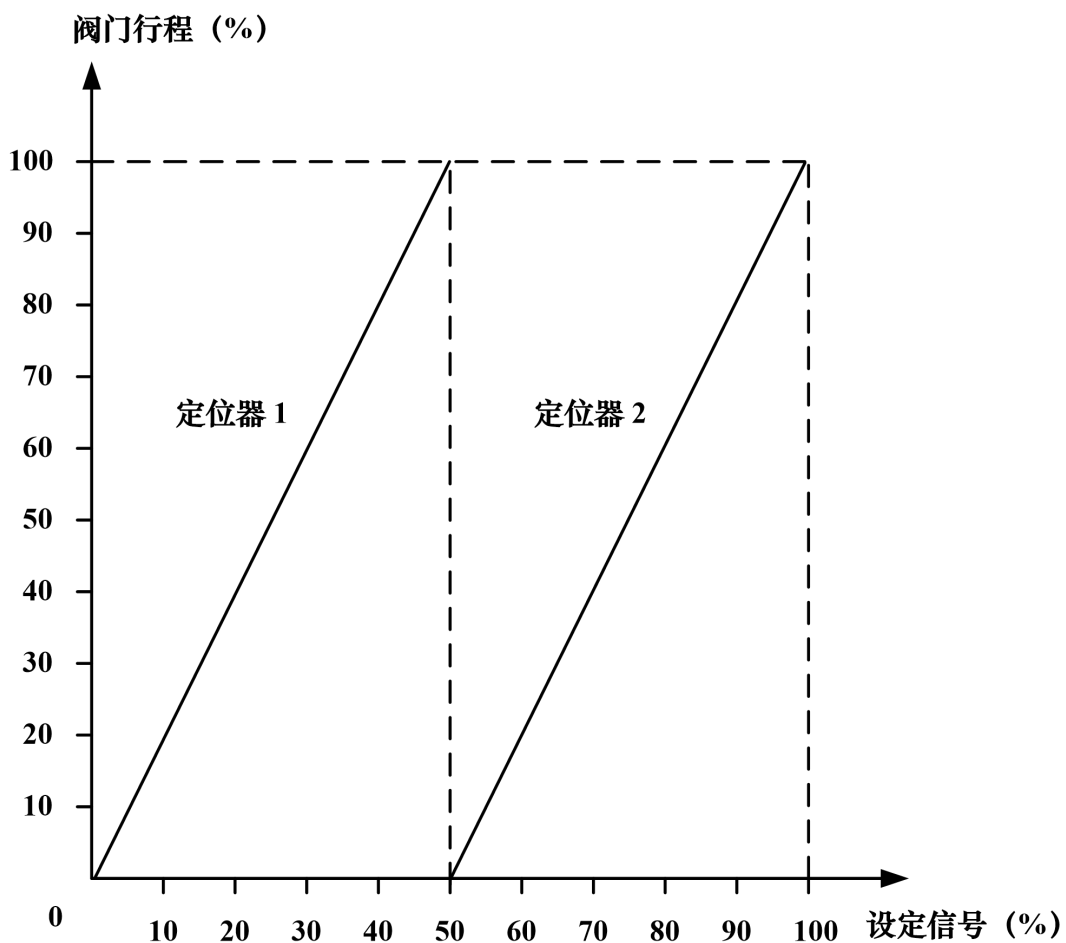
菜单中选择此功能，按 \odot 键开启参数设置，参数闪烁显示。按 $\blacktriangledown/\blacktriangle$ 键设置参数，持

续按 键或 键可快速修改参数。按 键确认修改。

8.3.3. 初始化过程错误提示

提示标志	提示说明	推测原因	处理方法
ERR 1	执行器动作错误	<ul style="list-style-type: none"> ● 无气源压力或气源压力不够。 ● 定位器或阀门存在漏气。 	<ul style="list-style-type: none"> ● 检查气源和气源压力，确保供气正常。 ● 消除漏气问题。
ERR 2	匹配的阀门行程不满足要求。	<ul style="list-style-type: none"> ● 阀门行程和传感器量程不匹配。 ● 阀门行程过短。低于最小行程要求。 ● 手动初始化时，手动标定的 END 1 和 END 2 两个行程端点的差值不满足要求。 	<ul style="list-style-type: none"> ● 选择合适量程的传感器和阀门匹配。 ● 如果是在手动初始化操作过程，则通过操作 <input type="checkbox"/> <input type="checkbox"/> 键重新标定 END 1 和 END 2,使两个行程端点间的传感器百分比差值大于 15%

8.3.4. 菜单选项或功能无法访问提示

当设置菜单选项参数或运行初始化时可能会出现如下标志来提示无法访问。具体说明见下表。

提示标志	提示说明
P1	写保护开启。

8.3.5. 菜单功能选项汇总说明

选项	功能	参数值	出厂设置
1 TYPE	执行机构类型设置	Lin Turn	Lin
2 INITA	自动初始化		
3 INITM	手动初始化		
4 CAL→4 mA	4mA 设定信号校正	当前信号 AD 值	800

4 CAL→20 mA	20mA 设定信号校正	当前信号 AD 值	4000
5 SDIR	设定信号方向设置	riSE FALL	riSE
6 CHAR	特性曲线选择	Lin 1:25 1:33 1:50 n1:25 n1:33 n1:50 FrEE	Lin
7 FREE→FR 0, FR 5...FR100	自定义参数设置	0.0% – 100.0%	0.0% 5.0% etc. to 100.0%
8 DB	死区设置	0.2 – 10.0%	1.0%
9 LIM→L MIN	行程限制功能最小值设置	0.0% – 100.0%	0.0%
9 LIM→L MAX	行程限制功能最大值设置	0.0% – 100.0%	100.0%
10 YDIR	设定值显示、位置值显示以及位置反馈信号输出的动作方向设置	riSE FALL	riSE
11 CUT→C MIN	紧闭功能最小值设置	0.0% – 100.0%	1.0%
11 CUT→C MAX	紧闭功能最大值设置	0.0% – 100.0%	100.0%
12 POS	位置显示和反馈信号输出标准设置	FS LS	FS
13 FACT	恢复出厂设置		
14 WP	写保护	oFF on	oFF
15 ACT	作用方式选择		
17 REC→HOURS	运行小时数	0-876000	0
17 REC→P CNT	正向偏差次数	0-99999	0
17 REC→N CNT	负向偏差次数	0-99999	0
17 REC→CLR	清空数据记录		
17 REC→S/W	开启或关闭数据记录	oFF on	on
18 LCD	显示屏显示方向	uP do	uP
A PST→S/W	开启或关闭 PST	oFF on	oFF
A PST→STPOS	PST 起始位置设置	0.0% – 100.0%	100.0%
A PST→RANGE	PST 起始位置容差范围设置	0.2% – 10.0%	2.0%
A PST→STEP	PST 步进行程设置	1.0% – 98.8%	10.0%

A PST→DIR	PST 行程方向设置	uP do uPdo	do
A PST→TIME	PST 限制时间设置	1s – 100s	50s
20 SPLIT→S MIN	分程控制功能最小值设置	0.0% – 70.0%	0.0%
20 SPLIT→S MAX	分程控制功能最大值设置	30.0% – 100.0%	100.0%
21 EXT	行程端点位置值优化显示	0.0% – 10.0%	0.0%

8.4. HART DD 文件和 DTM 文件说明

8.4.1. 设备动态变量说明

动态变量	描述
PV	位置设定百分比值
SV	位置百分比值

8.4.2. 设备自定义功能说明

设备自定义功能在 DD 文件和 DTM 文件的 **Detailed setup** 目录下。功能选项和描述如下表所示：

功能选项	描述
TYPE	详见 8.3.2.1 章节。
INIT	自动初始化运行或停止，初始化状态指示。 初始化功能详见 8.3.2.2 章节和详见 8.3.2.3 章节。
SDIR	详见 8.3.2.5 章节。
CHAR	详见 8.3.2.6 章节。
FREE	详见 8.3.2.7 章节。
DB	详见 8.3.2.8 章节。
LIM	详见 8.3.2.9 章节。
YDIR	详见 8.3.2.10 章节。
CUT	详见 8.3.2.11 章节。
POS	详见 8.3.2.12 章节。
FACT	详见 8.3.2.13 章节。

REC	详见 8.3.2.16 章节。
Setpoint	设定值设置。
Status	系统状态指示。
DIAG→PST	详见 8.3.2.19.1 章节。

INIT 目录下的功能选项和描述如下表所示：

功能选项	描述
INIT status	初始化状态指示。
INIT start	自动初始化开始。
INIT stop	自动初始化停止。

INIT status 状态标识和描述如下表所示：

状态标识	描述
NOINI	未初始化。
FINSH	初始化完成。
STEP1, STEP2, STEP3	初始化步骤。
ERR 1, ERR 2, ERR 3, ERR 4	初始化错误提示。

Setpoint 目录下的功能选项和描述如下表所示：

功能选项	描述
PV	设备动态变量。
SV	设备动态变量。
Setpoint source	设置设定值来源。可设置为 4-20mA 或 HART，默认为 4-20mA。当设置为 4-20mA 后，系统设定值由外部 4-20mA 信号决定。当设置为 HART 后，系统设定值由 HART 通讯输入设定值决定。目录跳出 HART Setpoint input 选项。它用于输入设定百分比值。
HART Setpoint input	通过 HART 通讯输入设定百分比值。

Status 目录下的功能选项和描述如下表所示：

功能选项	描述
Working status	系统工作状态。
Cutoff status	自动模式下紧闭状态。

Working status 状态标识和描述如下表所示：

状态标识	描述
NOINI	系统未初始化。
Config mode	系统在菜单配置模式或运行初始化功能。
Auto mode	系统在自动模式。
Manual mode	系统在手动模式。

Cutoff status 状态标识和描述如下表所示：

状态标识	描述
No	系统不在紧闭状态。
Cutoff down	系统对应 C MIN 紧闭。
Cutoff up	系统对应 C MAX 紧闭。

DIAG→PST 目录下的功能选项和描述如下表所示：

功能选项	描述
Parameters	PST 参数。
Test	操作 PST。

PST→Test 目录下的功能选项和描述如下表所示：

功能选项	描述
PST start	启动 PST 测试。
PST stop	停止 PST 测试。
PST status	PST 状态指示。

PST status 状态标识和描述如下表所示：

状态标识	描述
Not running	PST 未运行。
Running	PST 运行中。
SUCS	PST 成功。
FAIL	PST 失败。

8.5. 反馈信号

定位器可选配输出 4-20 mA 的反馈信号。反馈信号用来指示阀门位置百分比。

定位器的反馈信号模块为二线制，需要额外加 24V 直流电源供电。进入菜单后，反馈信号输出将停止更新。

8.6. 流量调节

1. 取下电路板保护盖



图 34. 拆除电路板保护盖

注意：请在设备断电情况下拆装电路板保护盖。

2. 调整节流杆位置

- 对于小型执行机构而言，节流杆可减少空气输出，增加定位稳定性。为此，可使用节流杆 Y1①和 Y2②。
- 使用一字螺丝刀顺时针转动节流杆，可减少空气输出直至最终切断输出。
- 设置节流杆时，建议先将其关闭，然后再缓慢打开。
- 双作用阀的情况下，确保两个节流杆的设置位置相仿。

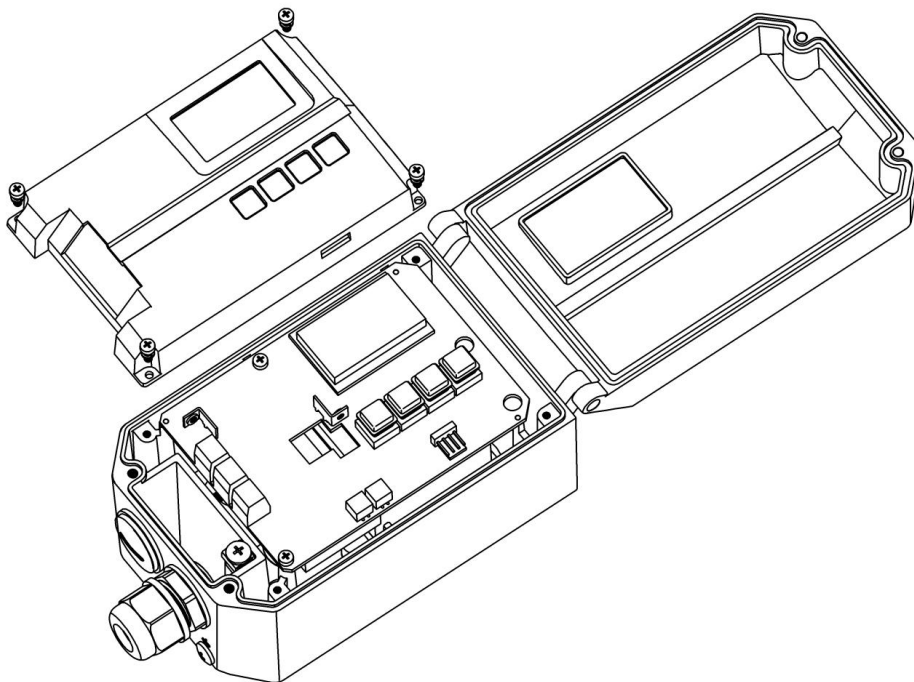

图 35.流量调节

- ① 节流杆 Y1
- ② 节流杆 Y2，仅适用于双作用执行机构版本。

9. 故障检修

内容	推测原因	处理方法
LCD 无显示	电气接口连接错误	请确认定位器的电气连接
	电流源没有电流输出	确认输入电流源是否有电流输出
	使用超出规格范围的输入电流源	请使用正常的输入电流源
	其他	请向本公司询问
OUT1 或 OUT2 口无空气输出 (完全没有动作)	供气压力不正常	请确认供气压力减压阀的设定
	没有输入电流	请正确输入电流 (4-20mA DC)
	配管漏气	请确认配管及管头, 阻止泄露
	其他	请向本公司询问
精度不好 (线性、 滞后现象)	供气压发生变动	请确认供气压力减压阀是否有异常
	定位器安装螺栓松动	请确认定位器的安全螺栓紧固
	定位器和执行器的连接部有间隙	请确认定位器的连接方式
	设定值有偏差	请对电流源输出信号进行调整
		对设定信号进行校正
其他	请向本公司询问	

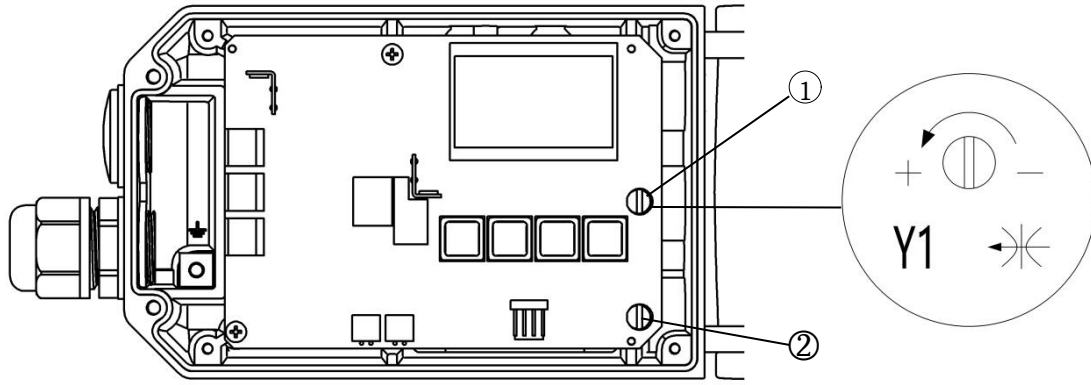
10. 保修条款

1. 发现产品有质量问题，经我公司人员确认后，客户享有在质保期内免费更换或维修的售后服务。服务响应时间为 24 小时（非工作日除外）。
2. 产品的质保期以本公司最新质保政策为准，不低于售出后 12 个月。
3. 如下情况的返修品，不属质保范围：
 - (1) 超过质保期的产品。
 - (2) 未经我公司授权和允许，私自拆装过的产品。
 - (3) 未按产品使用说明书操作或其他人为因素造成的产品损坏，包括但不限于：
 - 1> 产品表面有碰撞伤痕。
 - 2> 接线或供电错误造成元器件损坏。
 - 3> 零部件或配件丢失。
 - 4> 未加装过滤减压器或油雾分离器导致油污进入产品内部造成元器件损坏。
 - 5> 未按使用规范使用防水电气接头导致产品损坏。
 - 6> 堵塞或者私自拆除防水透气阀。
 - (4) 不可抗拒因素（自然灾害）造成产品故障或损毁。
4. 不属于产品质保范围的维修，我公司将视实际情况提供免费或收费维修服务。
5. 本条款自双方签定供货合同时生效。

Contents

1. Overview	47
2. One-key automatic initialization	47
3. Selection and ordering data	49
4. Technical data	50
5. Connection description	53
6. Dimension	55
6.1. Mechanical dimension	55
6.2. Mounting bracket dimension	56
6.3. Dimension of magnet	59
7. Installation	61
7.1. Linear stroke	61
7.2. Rotary stroke	63
7.3. Installation notes	66
7.4. Position feedback module	66
8. Operation	69
8.1. Interface description	69
8.2. Display and operation of main interface	70
8.3. Menu and functions	71
8.3.1. Display and operation of menu	71
8.3.2. Functions description and operation	71
8.3.2.1. TYPE	71
8.3.2.2. INITA	72
8.3.2.3. INITM	72
8.3.2.4. CAL	72
8.3.2.5. SDIR	73
8.3.2.6. CHAR	74
8.3.2.7. FREE	75
8.3.2.8. DB	76
8.3.2.9. LIM	77
8.3.2.10. YDIR	77
8.3.2.11. CUT	78
8.3.2.12. POS	78
8.3.2.13. FACT	79
8.3.2.14. WP	80

8.3.2.15.	ACT	80
8.3.2.16.	REC	80
8.3.2.17.	LCD	81
8.3.2.18.	DIAG	81
8.3.2.19.1.	PST	81
8.3.2.19.	SPLIT	82
8.3.2.20.	EXT	82
8.3.3.	Error message during initialization	83
8.3.4.	Tips of menu option or function cannot access	83
8.3.5.	Menu function options summary description	84
8.4.	HART DD file and DTM file description	85
8.4.1.	Device dynamic variable description	85
8.4.2.	Device custom function description	86
8.5.	Feedback signal	88
8.6.	Adjust air flow	88
9.	Trouble shooting	90
10.	Warranty terms	91



1. Overview

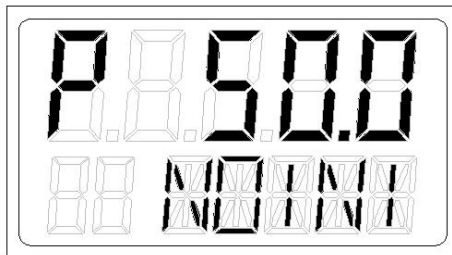

IP7000 series intelligent valve positioner is mounted on pneumatic actuators. It's used to control air intake and exhaust of the pneumatic actuators to drive the valve position to the set point by calculating both data from 4-20 mA DC signal and feedback position.

2. One-key automatic initialization

1. Please read the installation instructions in **chapter 7** before installing the positioner. Install the positioner according to the installation requirements described. Please pay attention to some installation points. For example, confirm the initial position of the feedback axis of the positioner or remote sensor before installation. Do not turn the feedback axis 360° during installation. For the positioner of normal linear type, make the upper plane of the positioner housing at a right angle to the main stem of the valve. Within the valve stroke range, the rotation angle of the positioner feedback lever meets the installation requirements.
2. After installing the positioner on the valve, connect the air source and electrical cables. Ensure that the air source pressure can fully open the valve. Power on the positioner by inputting a 4-20mA signal.
3. After the positioner is powered on, Positioner is in the uninitialized state before initialization. When LCD displays the sign **NOINI**, interface displays percentage value of sensor in the top line. As shown below.



In this state, pressing   buttons can open and close valve. Open and close valve fully, and observe the percentage value of sensor displayed on the interface. Ensure that within the entire valve stroke range, the sensor percentage value changes monotonically. Otherwise, it is necessary to re-adjust the installation position. In addition, the minimum and maximum percentage difference of the sensor is required to be greater than 15%.

4. The actuator type has been set before the positioner leaves the factory. The user only needs one-key operation to execute the automatic initialization (**INITA**) function to complete the matching of the valve. In the initial interface (**NOINI**) or manual / automatic mode interface, press and hold  button for approx. 3s to run the automatic initialization. After the initialization is completed, **FINSH** is displayed on the LCD, press  button to exit. After exiting, the system enters the manual mode interface, press  button again to switch to the automatic mode. At this time, the user can control the valve position through the 4-20mA signal.

For some reasons, the system will display an error message in the function option line during the automatic initialization process and the automatic initialization will be interrupted. Descriptions of error messages and solutions are showed in chapter 8.3.3.

3. Selection and ordering data

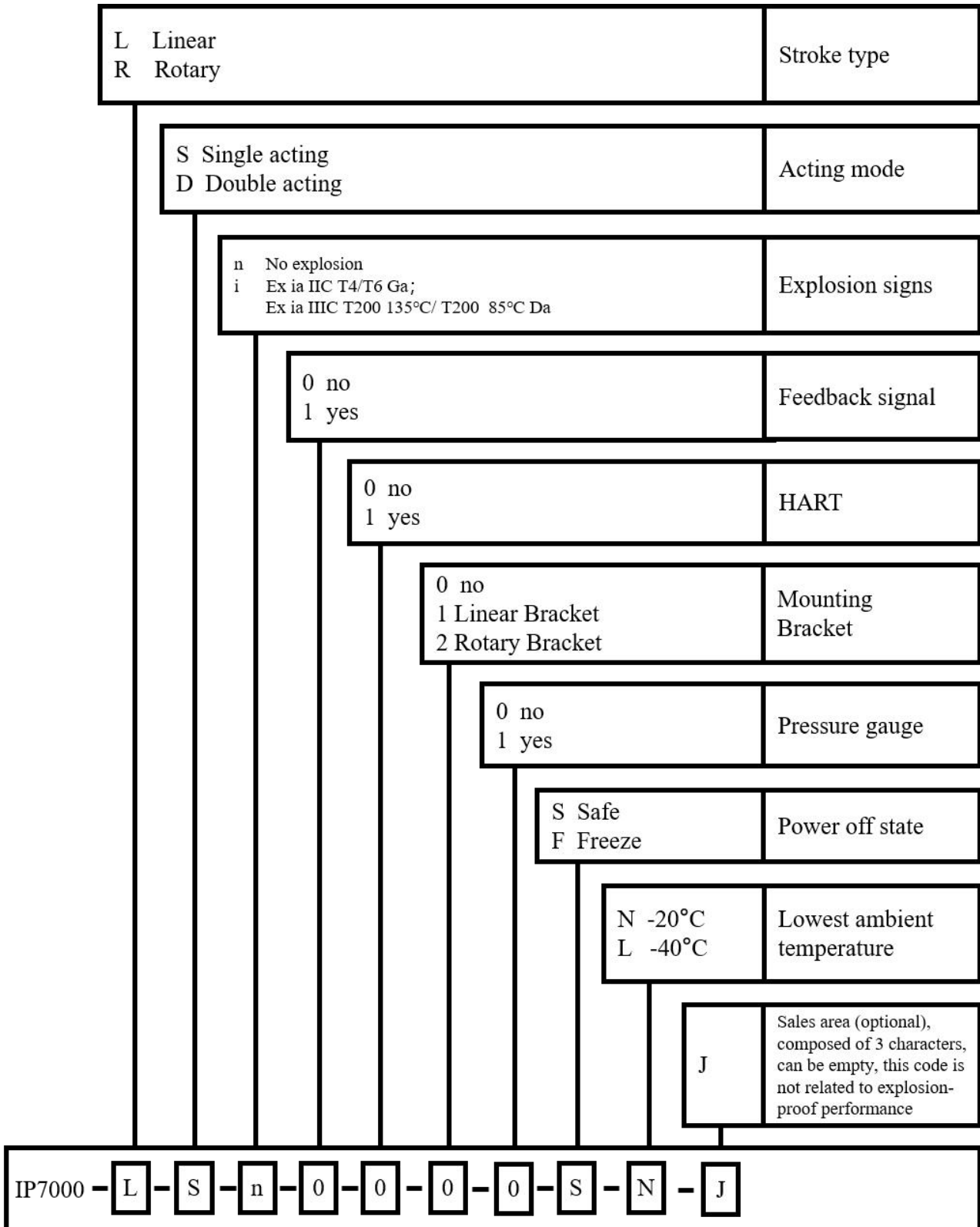

4. Technical data

Shell material	Aluminum
Set-point signal	4-20mA DC, no-load voltage: 15-24V DC
Minimum working current	3.8mA
Input resistance	120Ω
Ambient temperature	<p>Normal version for non-explosion-proof: -20°C ~ +80°C</p> <p>Optional version for non-explosion-proof: -40°C ~ +80°C</p> <p>Normal version for explosion-proof: -20°C ~ +80°C (T4) , -20°C ~ +40°C (T6)</p> <p>Optional version for explosion-proof: -40°C ~ +80°C (T4) , -40°C ~ +40°C (T6)</p> <p>The device display will be dull or not displayed below -20°C.</p>
Gas source requirement	<p>ISO 8573-1</p> <ul style="list-style-type: none"> ● Solid particle size and density Class 3 ● Dew point Class 3 ● Oil content Class 3
Vibration resistance	<p>0.15mm,10Hz-60Hz,20 cycle/axis 20m/ s²,60Hz-500Hz,20 cycle/axis</p> <p>Recommended range for control valve ≤ 20 m/s², no resonance peak</p>
Supply pressure	0.14~0.7MPa
Flow	<ul style="list-style-type: none"> ● Input air <ul style="list-style-type: none"> 2 bar 4.8 Nm³/h 4 bar 8.0 Nm³/h 6 bar 11.2 Nm³/h ● Exhaust air(Safe) <ul style="list-style-type: none"> 2 bar 5.9 Nm³/h 4 bar 9.8 Nm³/h 6 bar 13.7 Nm³/h ● Exhaust air (Freeze) <ul style="list-style-type: none"> 2 bar 6.6 Nm³/h 4 bar 11.1 Nm³/h 6 bar 15.6 Nm³/h
Steady state air consumption	≤ 0.4 L/min
Basic error	≤ 1.0%
Hysteresis error	≤ 1.0%

Electrical connection	1/2NPT (default) or M20x1.5, please contact with sales for other thread specifications
Pneumatic connection	1/4NPT (default) or G1/4, please contact sales for other thread specifications
Weight	2.0 kg
Protection class	IP69K
Explosion signs	Ex ia IIC T4/T6 Ga; Ex ia IIIC T200 135°C/ T200 85°C Da;

Electrical parameters for intrinsic safety:

loop name	Maximum input voltage Ui (V)	Maximum input current Ii (mA)	Maximum input power Pi (W)	Maximum internal equivalent parameters	
				Ci (nF)	Li (mH)
4~20mA setting	28	93	0.66	approximately zero	
4~20mA output	28	93	0.66	approximately zero	

Special restricted use conditions:

1) Operating temperature range:

Minimum operating ambient temperature: -40°C。

The relationship between the maximum operating ambient temperature and temperature group/maximum surface temperature is shown in the table below:

maximum operating ambient temperature (°C)	temperature group/maximum surface temperature
+80°C	T4/T ₂₀₀ 135°C
+40°C	T6/T ₂₀₀ 85°C

2) When the product is installed in a location requiring EPL Ga classification, the user must take effective measures to prevent the ignition hazard caused by impact or friction on the product's casing.

3) At least the following measures should be taken to prevent the accumulation of electrostatic charges on the product casing:

- a Control the relative humidity of the environment to minimize the generation of static electricity.
- b Do not dry rub or blow the surface of the product casing to prevent the risk of ignition due to static electricity.

4) The associated device should preferably use an isolating safety barrier; if a zener safety barrier is chosen, it should comply with the requirements of the GB 3836.15-2024 standard regarding the grounding of intrinsically safe circuits.

Notes:

The installation, use, and maintenance of the product should comply with both the product manual and the following relevant standards:

GB/T 3836.13 – 2021 Explosive atmospheres—Part 13: Equipment repair, overhaul, reclamation and modification

GB 3836.15 – 2024 Explosive atmospheres – Part 15: Specification of electrical installations design, selection and erection

GB 3836.16 – 2024 Explosive atmospheres—Part 16: Specification of electrical installations inspection and maintenance

GB/T 3836.18 – 2024 Explosive atmospheres—Part 18: Intrinsically safe electrical systems

GB 15577 – 2018 Safety regulations for dust explosion prevention and protection

GB 50257 – 2014 Code for construction and acceptance of electric equipment on fire and explosion hazard electrical equipment installation engineering

5. Connection description

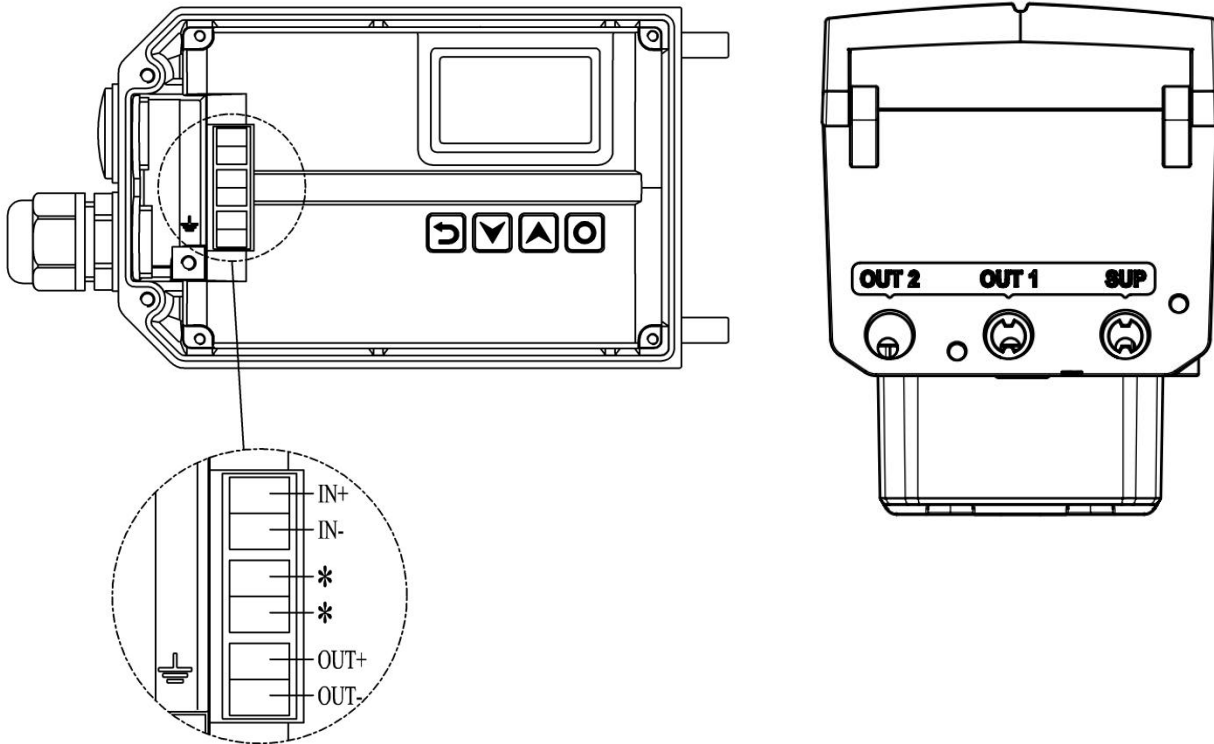

Figure 1. Connection description

Electrical Connection	Description
IN+	4-20 mA set-point signal +
IN-	4-20 mA set-point signal -
OUT+	Feedback signal module 18-30 V DC +
OUT-	Feedback signal module 4-20 mA output
*	The two interfaces are connected with each other, and the device is in low impedance mode. (In low impedance mode,

Pneumatic Connection	Description
SUP	Air supply enter
OUT1	Pilot air outlet 1
OUT2	Pilot air outlet 2, used for double acting type.

	the HART communication function will be disabled.)
--	--

Remarks: For the separate type of the positioner, OUT1 and OUT2 are blocked and not used.

NOTES:

- **Electrical cables must use shielded twisted pair or shielded wires. Connect one end of the cable shielding layer to the \perp screw inside the casing, and the other end to the ground. So that the device is effectively grounded to prevent electromagnetic interference.**
- **Keep electrical cables away from strong magnetic fields.**
- **Must install or remove the electrical cable when the device is powered off.**
- **If the input signal has attenuation and the user does not require HART communication function, try to set to low impedance mode. Connect the two undefined electrical interfaces marked with * in Figure 1 to each other through one wire to make the positioner in low impedance mode.**
- **If the split range control function of the positioner is to be used, a DC signal isolator must be used to convert one 4-20mA setting signal into two 4-20mA setting signals, and then connect them to two positioners respectively. Set the positioner to low impedance mode.**

HART communication wiring:

Connect the two signal wires of the HART modem or HART communicator to the positive and negative poles of the 4-20 mA setting signal.

6. Dimension

6.1. Mechanical dimension

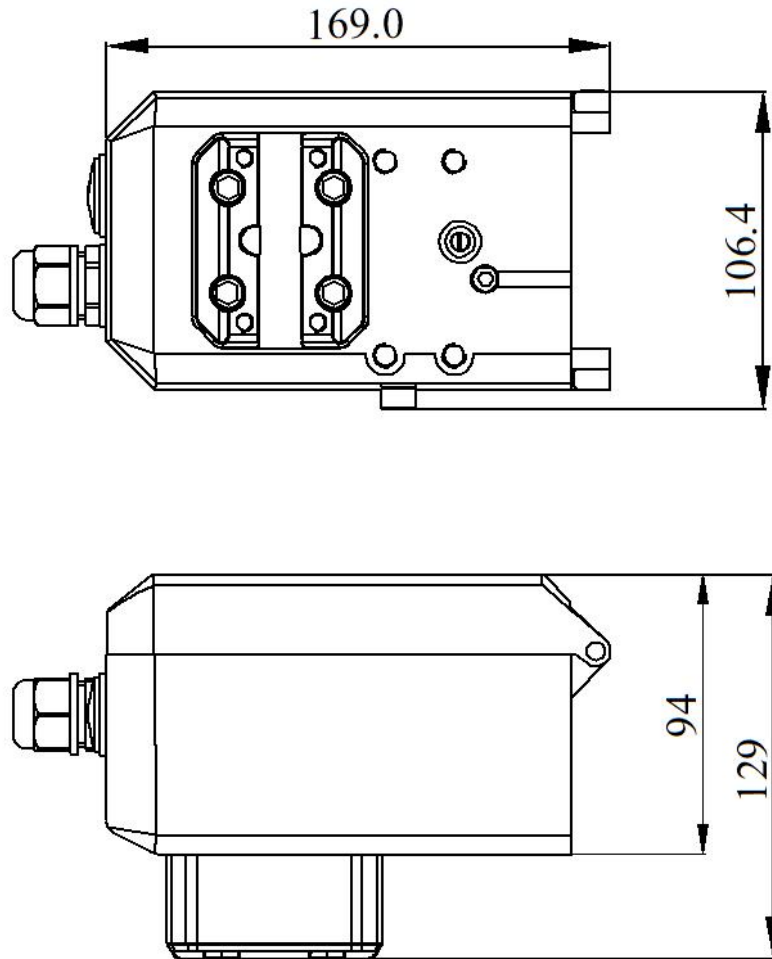

Figure 2. Mechanical dimension

6.2. Mounting bracket dimension

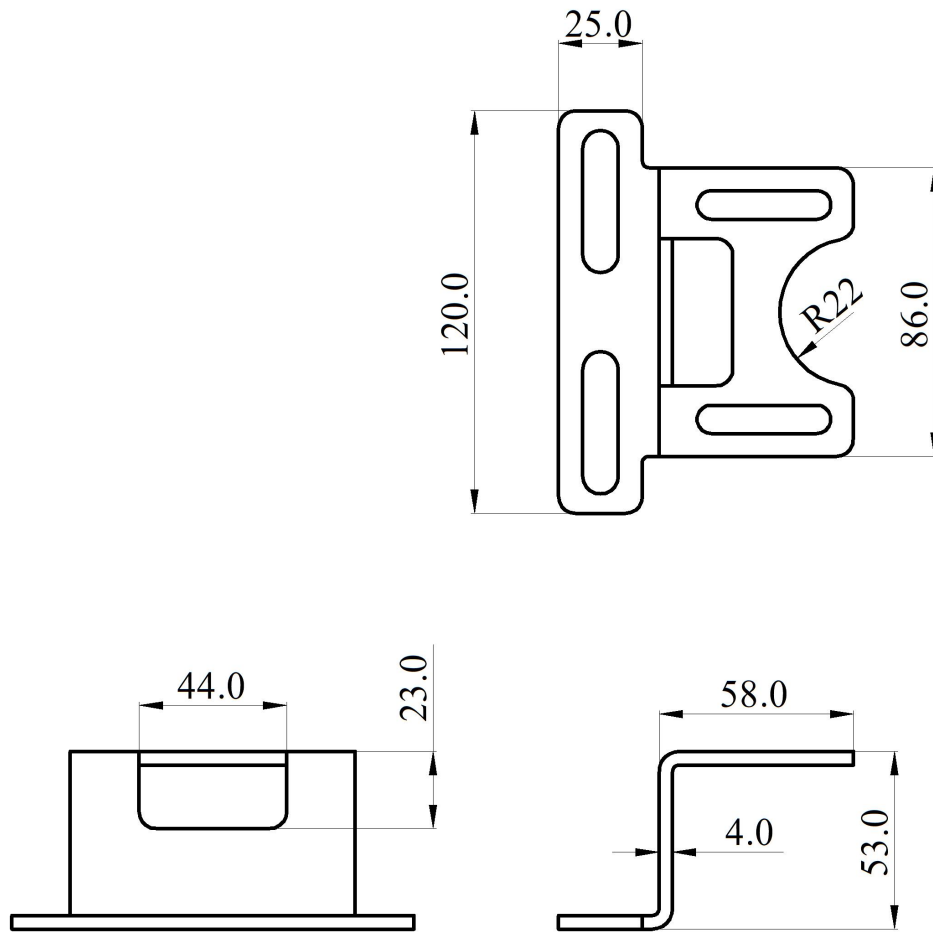

Figure 3. Normal linear mounting bracket

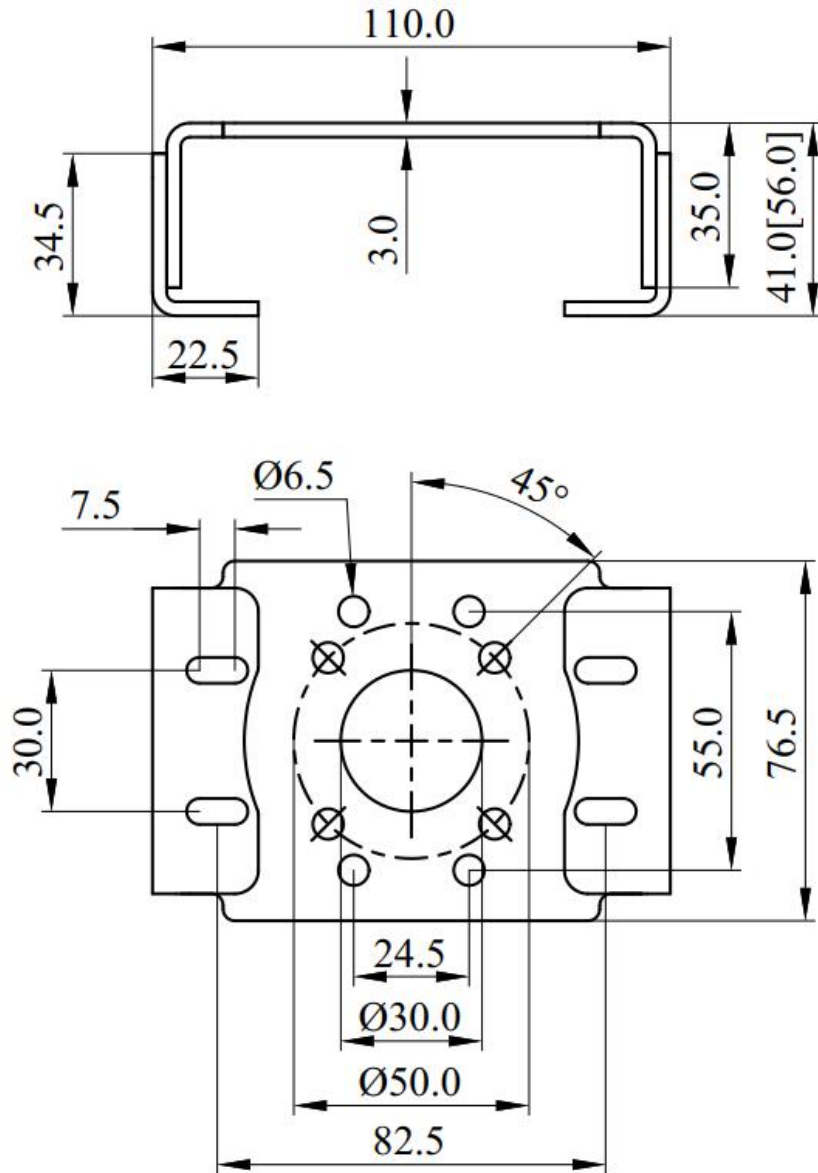

Figure 4. Rotary mounting bracket (Type A)

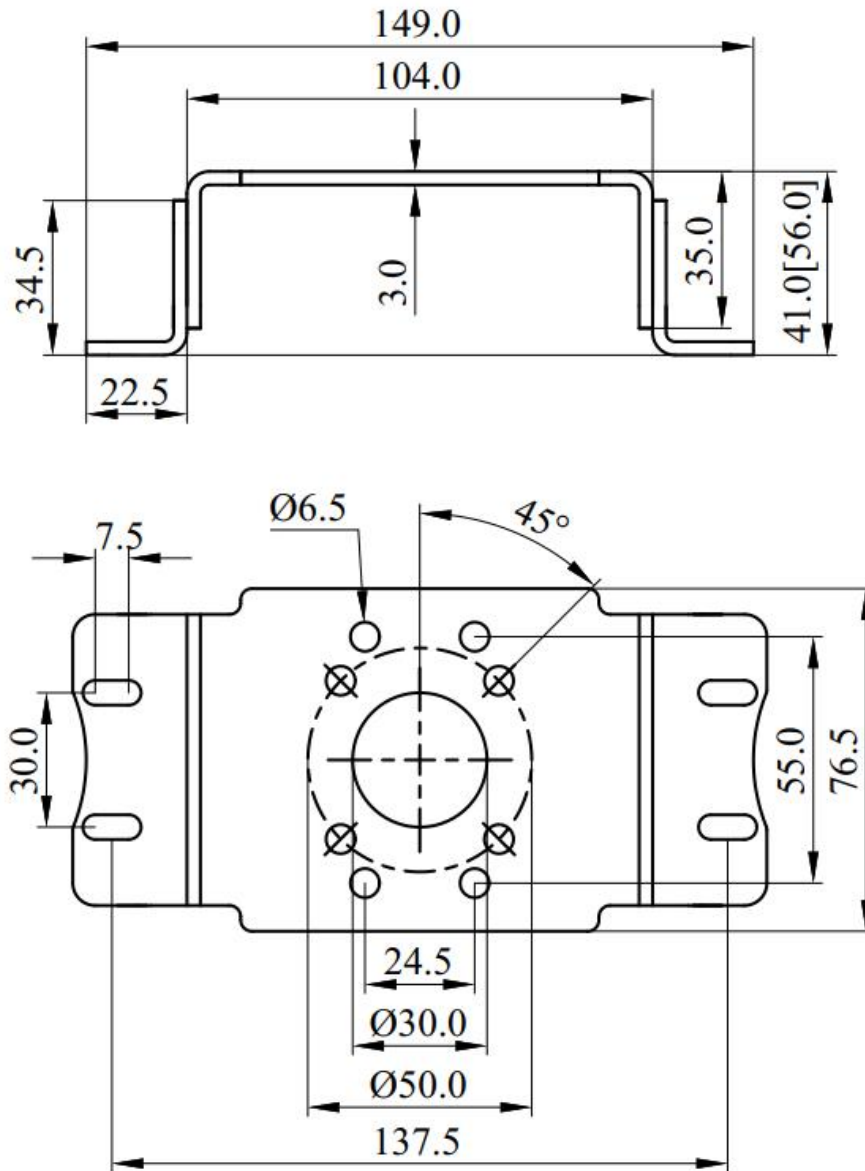

Figure 5. Rotary mounting bracket (Type B)

6.3. Dimension of magnet

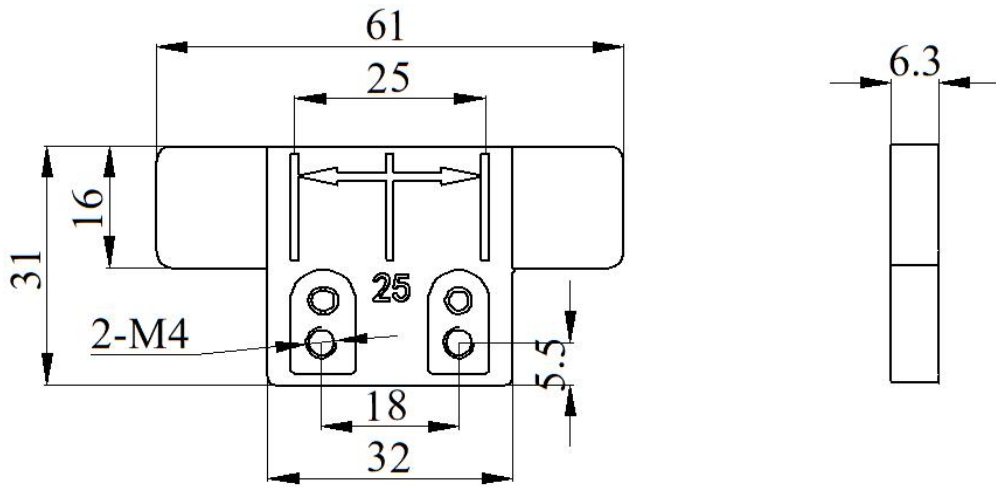

Figure 6. 25mm magnet (stroke range:10-25mm)

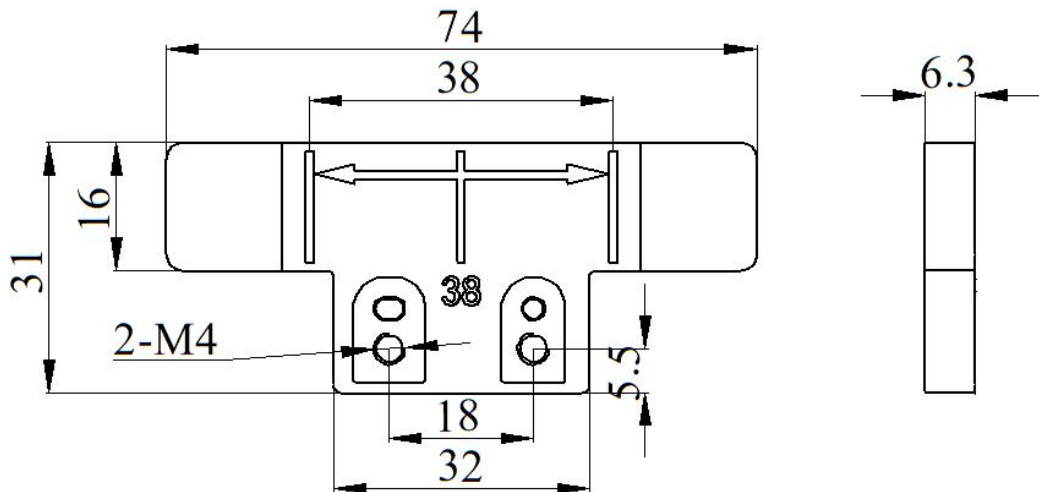

Figure 7. 38mm magnet (stroke range:25-38mm)

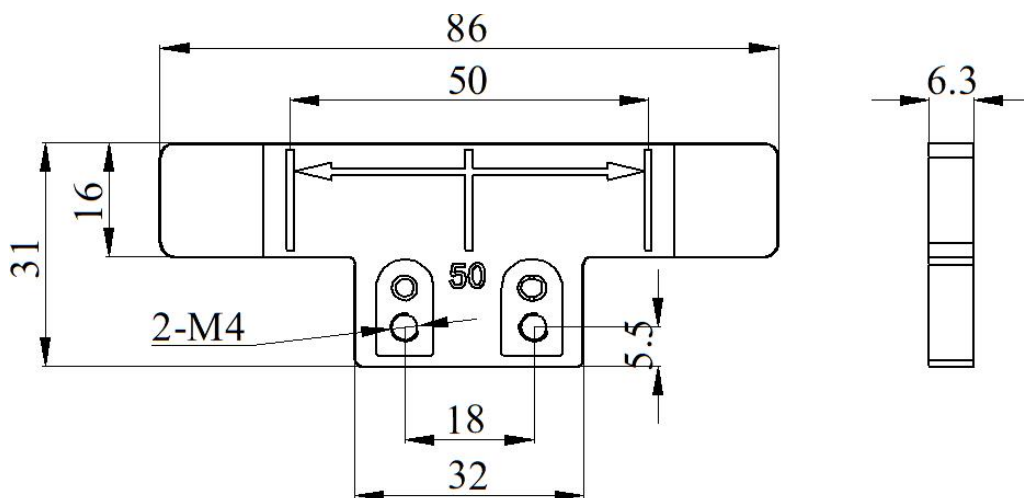

Figure 8. 50mm magnet (stroke range:38-50mm)

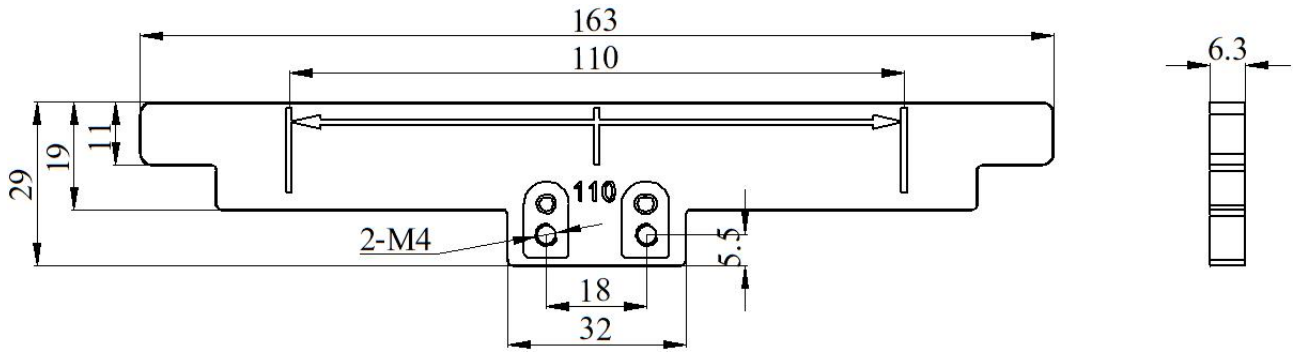

Figure 9. 110mm magnet (stroke range:50-110mm)

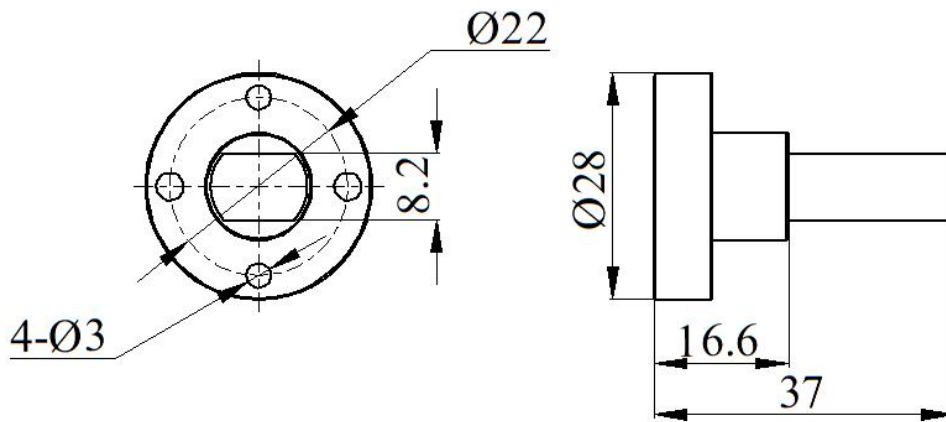

Figure 10. Rotary stroke magnet

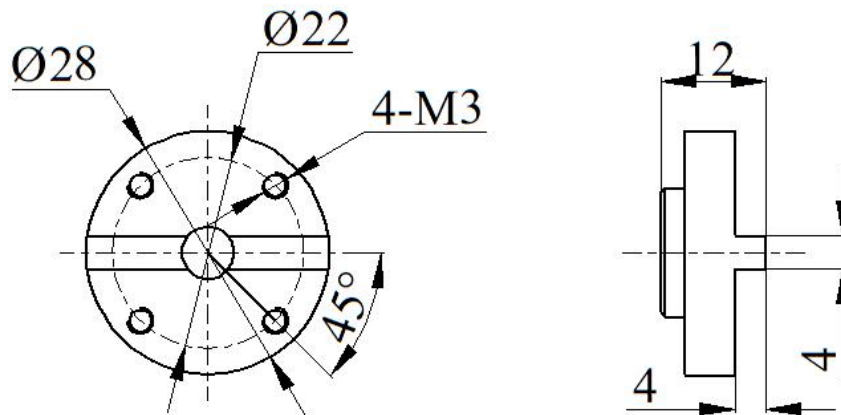

Figure 11. Connector for rotary stroke magnet

7. Installation

7.1. Linear stroke

Linear actuator mounting components			
No.	Name	Amount	Note
①	Non-contact magnet	1	Select a specific magnet based on the valve stroke
②	Magnet mounting bracket	1	Adjust and fix the position of the magnet
③	M6 hexagon socket screw	2	M6×10 fixed magnet mounting bracket
④	M6 spring washer	2	Prevent screw loosening
⑤	M4 cross screw	2	M4×10 fixed magnet
⑥	M4 spring washer	2	Prevent magnet loosening
⑦	Linear stroke mounting bracket	1	Connect positioner and actuator
⑧	M8 hexagon head bolts	2	M8×10
⑨	M8 spring washer	2	Prevent bolts loosening
⑩	M8 flat washer	2	Protect contact surface

1. Install the magnet mounting bracket onto the valve stem, and pre-tighten the magnet corresponding to the stroke on the bracket. If there is no mounting hole on the valve stem, a fork plate can be added at the valve stem position to assist in installation. Install the linear stroke mounting bracket onto the valve.

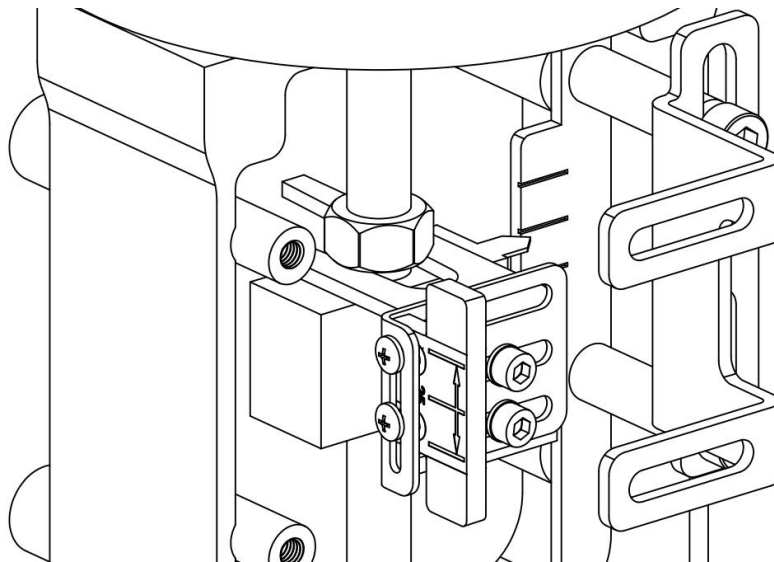

Figure 12. Installation of linear stroke mounting bracket and magnet bracket

2. Fix the positioner onto the mounting bracket and adjust its relative position to the magnet on both sides. It is required that the distance from the magnet to both sides of the chute be the same, as shown in the figure below. The depth of the magnet buried into the chute (D value)

should be between 10mm and 15mm.

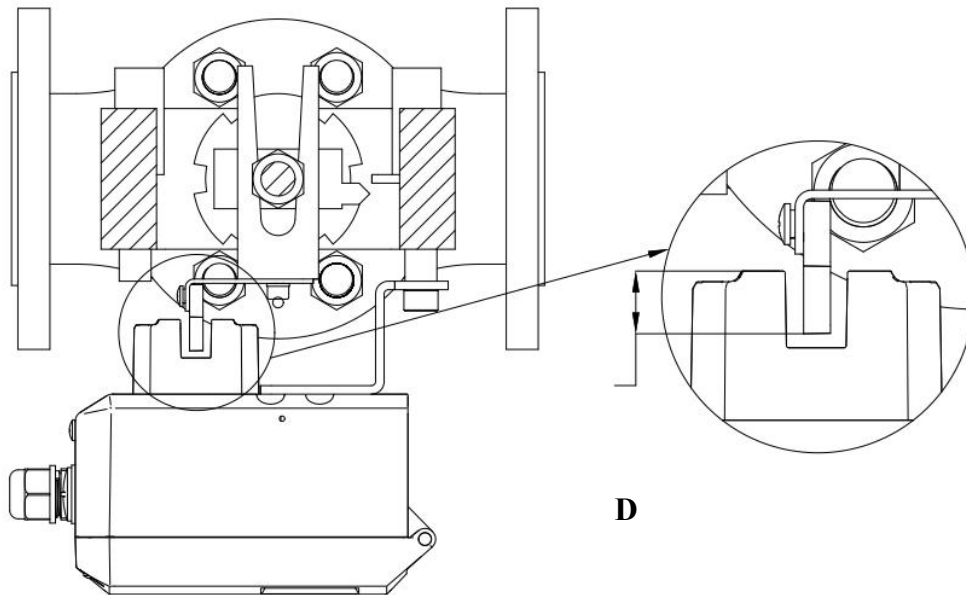

Figure 13. Installation of positioner and linear actuator

3. Adjust the vertical position of the magnet relative to the positioner. Directly vent the actuator cylinder to open the valve to 50%. At this point, adjust the position of the magnet so that its center is also aligned with the center of the slide groove on the back of the positioner. It is also required that the magnet be installed parallel to the valve stem.

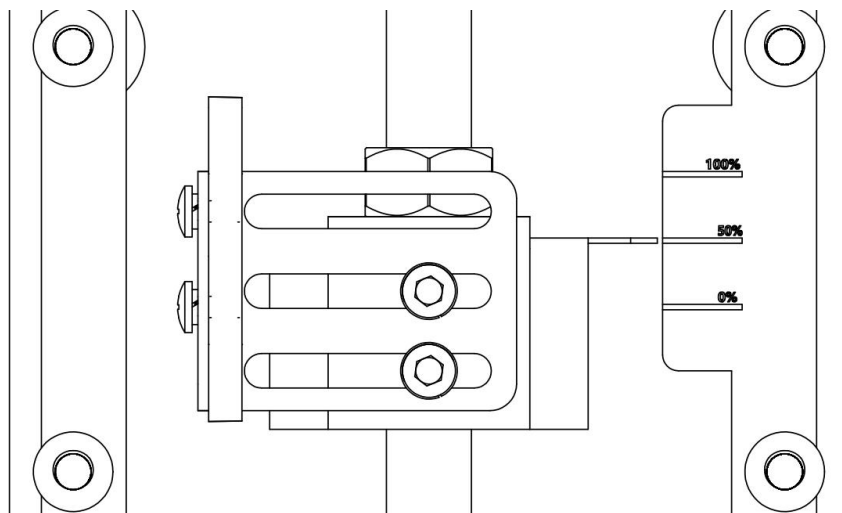

Figure 14. Directly vent the actuator cylinder to open the valve to 50%

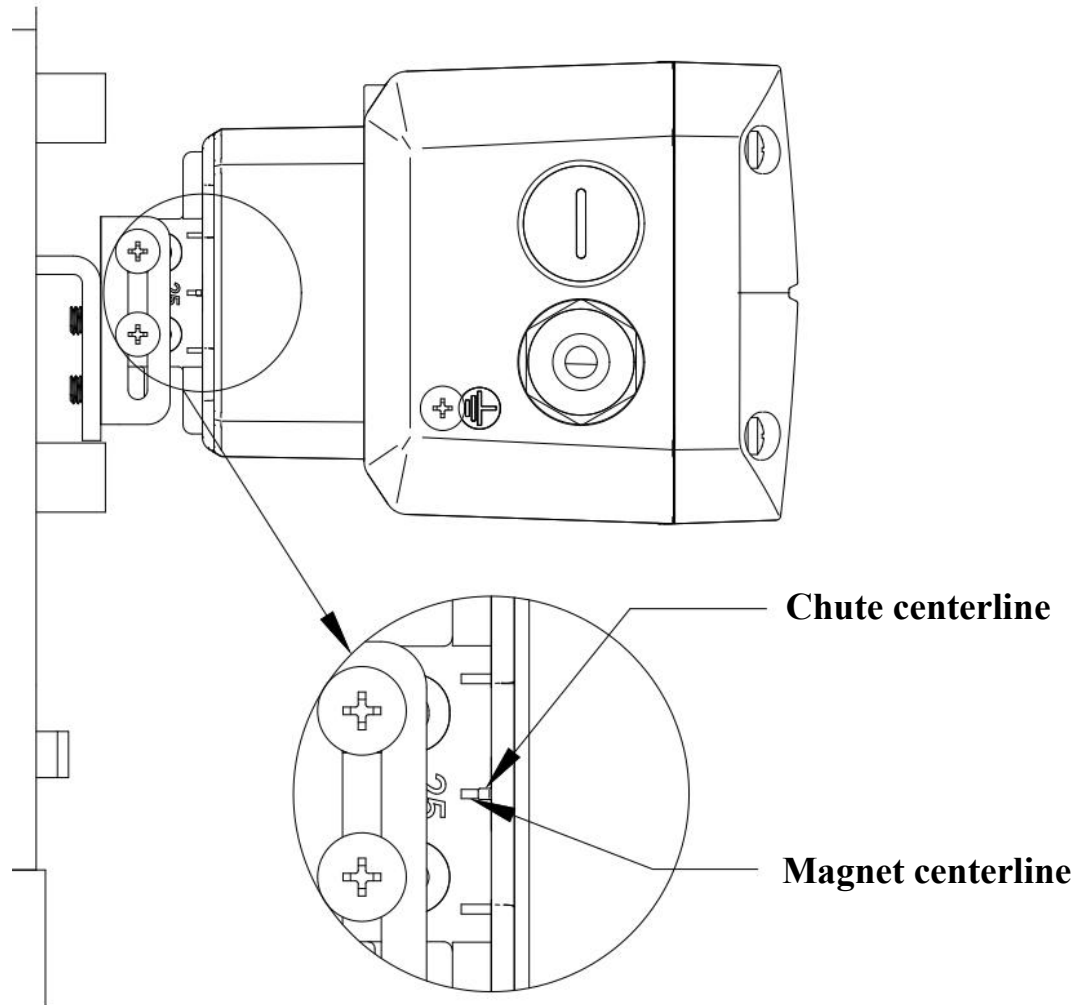

Figure 15. Align the center line of the magnet with the center line of the chute

7.2. Rotary stroke

Rotary actuator mounting components			
No.	Name	Amount	Note
①	Rotary stroke connector	1	Connect the magnet and the actuator
②	Rotary stroke magnet	1	Actuator compatible with 80°-100°
③	Rotary stroke mounting bracket	1	Compatible for actuators in different specifications.
④	M6 flat washer	4	Protect contact surface
⑤	M6 spring washer	4	Prevent screw loosening
⑥	M6 hexagon socket screw	5	M6×10 fixed positioner, rotary stroke connector
⑦	M5 hexagon socket screw	4	M5×8 fixed mounting bracket
⑧	M5 spring washer	4	Prevent screw loosening

⑨	M5 flat washer	4	Protect contact surface
⑩	M4 cross screw	4	M4×10 fixing magnet

1. Fix the rotary stroke connector onto the actuator. Insert the connecting piece into the slot of the actuator shaft and tighten it with an allen screw. Ensure that the connecting piece and the valve do not rotate relative to each other during valve movement.

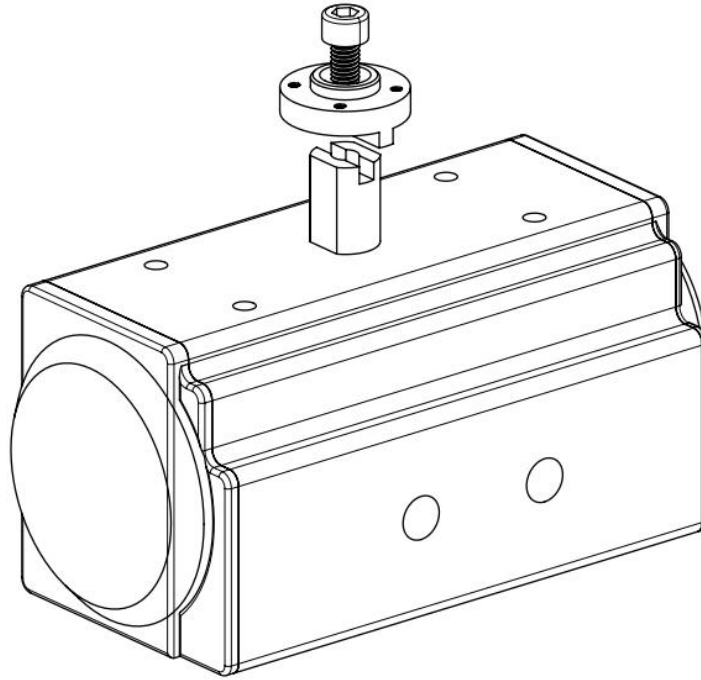
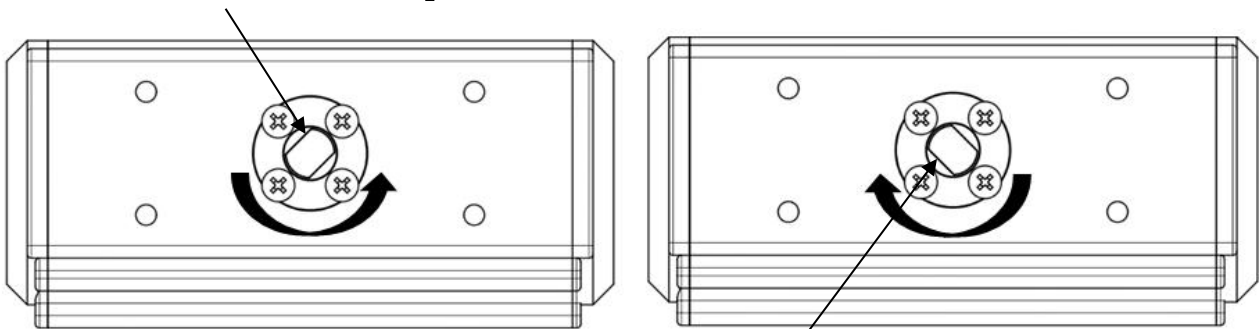

Figure 16. Install the rotary stroke connector

2. Install the rotary stroke magnet in the direction shown in the schematic diagram. It is required that the two flat surfaces on the side of the magnet should be at a 45° angle to the edge of the positioner slot that is about to be installed. Note that the initial installation direction of the magnet varies depending on the rotation direction of the valve. It is required that when the valve is at 50% open, the warning label should face left.

Label direction at initial position



Label direction at initial position

Figure 17. Install the rotary stroke magnet at the initial position of the valve

3. Install and secure the rotary stroke mounting bracket, positioner, and actuator as shown in the figure.

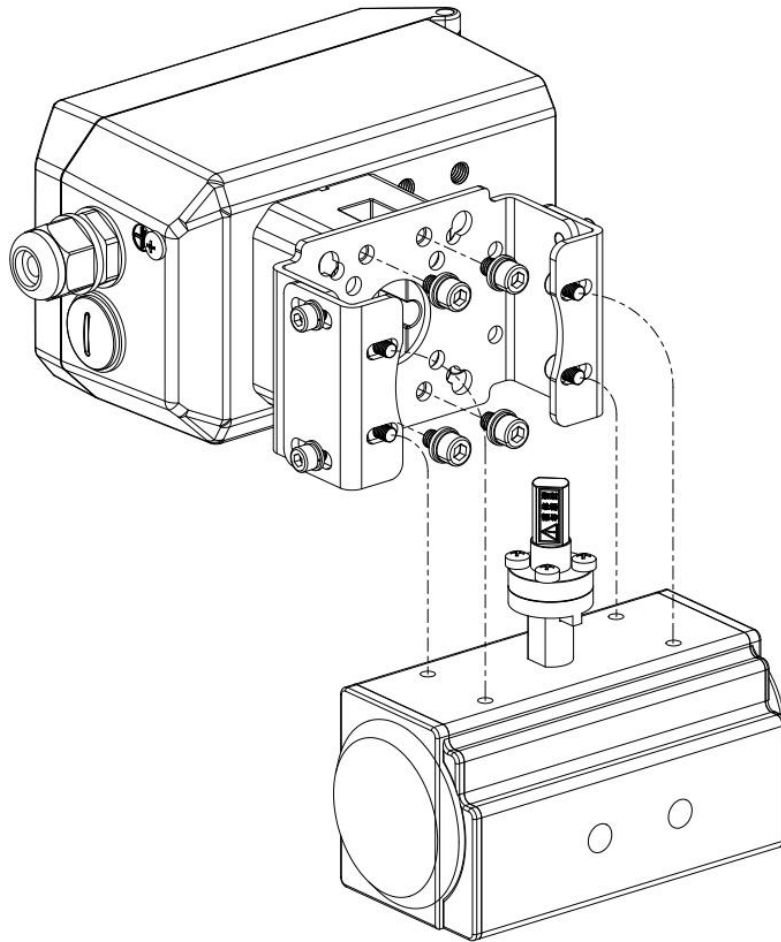

Figure 18. Installation of rotary stroke mounting bracket

4. Adjust the height of the bracket by tightening the fixing screws on both sides of the bracket. It is required that the magnet be positioned at the center of the sliding slot on the back of the positioner, and the depth of embedding of the magnet should be between 10mm and 15mm.

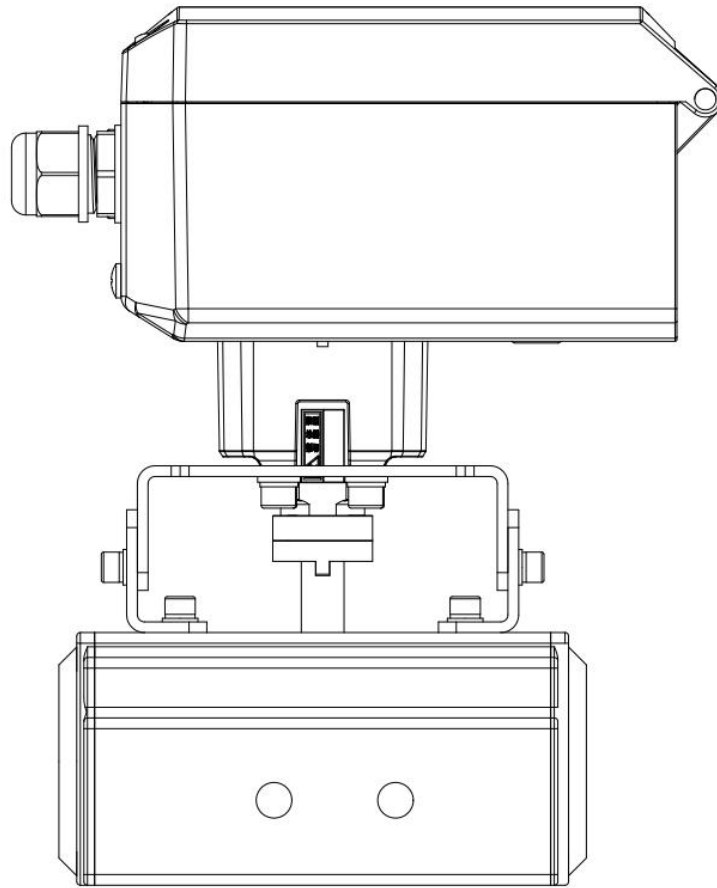

Figure 19. Adjust the height of the mounting bracket

7.3. Installation notes

- Do not install the positioner near high-magnetic equipment!
- The materials of the magnet assembly have been specially selected to provide a long-term stable magnetic field. However, like any magnet, the magnet assembly must be handled with care. Placing other high-magnetic magnets in close proximity to the device (less than 25 mm) may result in permanent damage to the device. Items that may damage the device include, but are not limited to: transformers, DC motors, and laminated magnet assemblies.
- Please do not place magnetic objects such as magnetic screwdrivers near the magnet, as these objects may affect valve control.

7.4. Position feedback module

If it is required, feedback module is available when user selects.

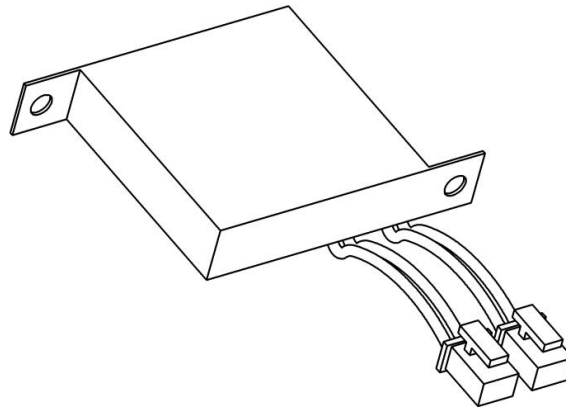

Figure 20. Feedback module

Installation of feedback module:

- Open the outer cover and take off the circuit board protective cover.

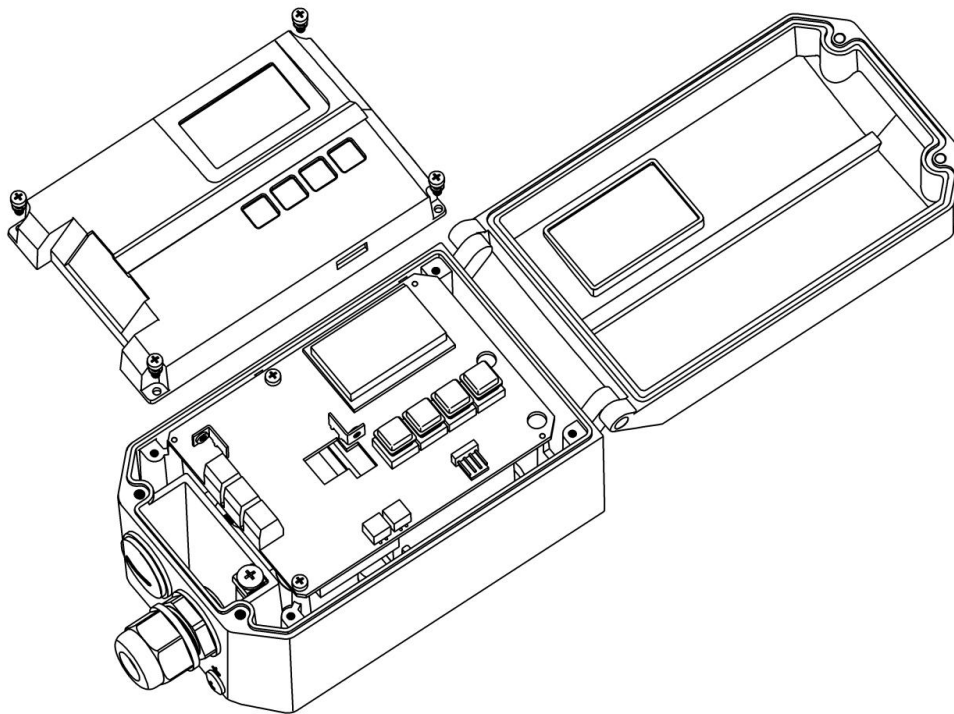

Figure 21. Remove the circuit board protective cover

- Install the feedback module according to the position as shown below, and connect electrical connectors of the module with the connectors on the circuit board according to the corresponding colors, fix the feedback module with M3 spring washer and M3 pan head screw, and finally install the circuit board protective cover.

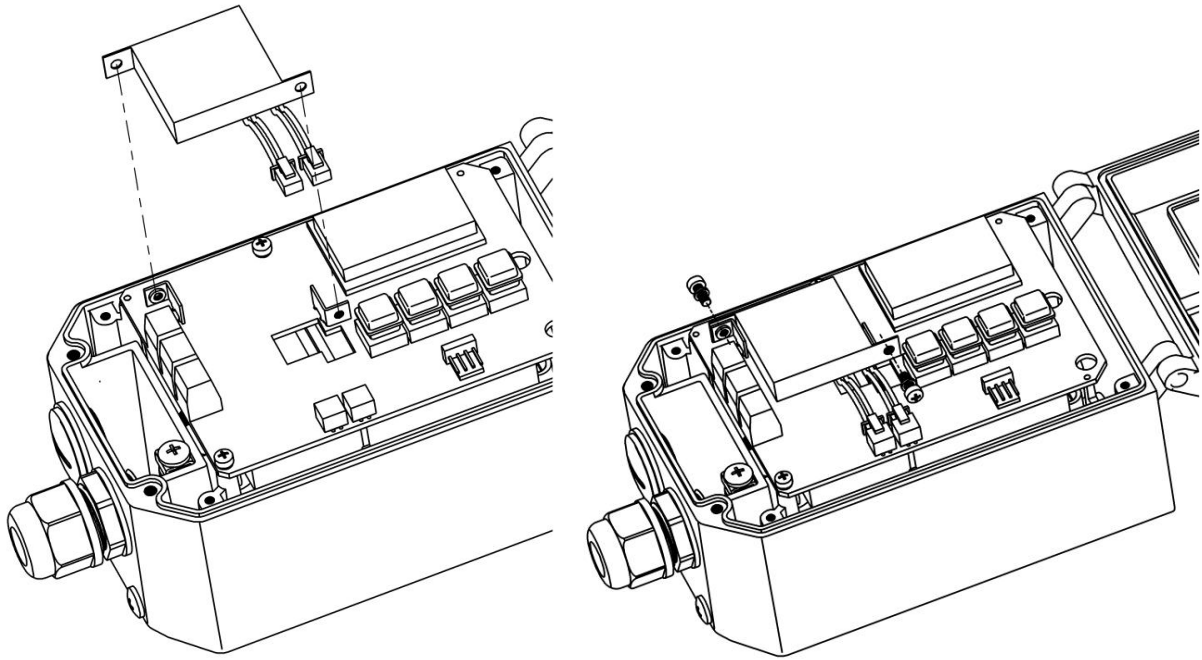

Figure 22. Feedback module installation

NOTE: Must install or remove the circuit board protective cover when the device is powered off.

8. Operation







8.1. Interface description

User's operating interface includes one LCD screen and 4 buttons.

LCD display description

Position	Description
Top line	<ul style="list-style-type: none"> ● Display the percentage value of angle sensor in the initial interface (NOINI) or when running the initialization function. ● Display valve position percentage value in operating mode. ● Display parameter values in menu mode.
Bottom line	<ul style="list-style-type: none"> ● Display indication signs in uninitialized state. ● Display automatic or manual mode in operating mode. ● Display setpoint percentage value in operating mode. ● Display function options in menu mode. ● Display initialization step and error sign in initialization process.

Button operation description

Button	Description
	<ul style="list-style-type: none"> ● Enter the system menu. ● Switch automatic and manual mode in operating mode. ● Exit from the system menu to main interface ● Exit from submenu to previous menu.
	<ul style="list-style-type: none"> ● Open or close valve in the initial interface (NOINI). ● Decrease the valve position value in manual mode. If press and hold this button first, then press and hold  button, the valve position value will be reduced quickly. ● Select function options or parameters down and decrease parameter values in menu mode.
	<ul style="list-style-type: none"> ● Open or close valve in the initial interface (NOINI). ● Increase the valve position value in manual mode. If press and hold this button first, then press and hold  button, the valve position value will be increased quickly. ● Select function options or parameters up and increase parameter values in menu mode.
	<ul style="list-style-type: none"> ● Enter submenu, enable or confirm parameter modification in menu mode. ● Run initialization or reset to factory settings.

- Run initialization in initial interface (NOINI) or in operating mode.

8.2. Display and operation of main interface

Positioner is in the uninitialized state before initialization. When LCD displays the sign **NOINI**, interface displays percentage value of sensor in the top line.

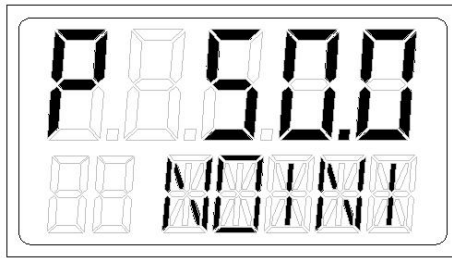

Figure 23. Uninitialized state interface

In this state, pressing \blacktriangledown \blacktriangle buttons can open and close valve. Open and close valve fully, and observe the percentage value of sensor displayed on the interface. Ensure that within the entire valve stroke range, the sensor percentage value changes monotonically. Otherwise, it is necessary to re-adjust the installation position. In addition, the minimum and maximum percentage difference of the sensor is required to be greater than 15%.

If you want to take a shortcut of running automatic initialization (**INITA**), press and hold \odot button for approx. 3s to run it in the initial interface (**NOINI**) or in the operating mode. In the initialization process, pressing \supset button will exit. After exiting, if the initialization is completed before, system enters manual mode interface. Otherwise, system enters initial interface (**NOINI**). After the initialization is completed, press \supset button to exit. After exiting, the system enters the manual mode interface.

Operating mode includes automatic mode and manual mode.

In automatic mode, system adjusts the valve position automatically by collecting the external 4-20mA input signal.

In manual mode, valve position can be adjusted by pressing \blacktriangledown \blacktriangle buttons manually.



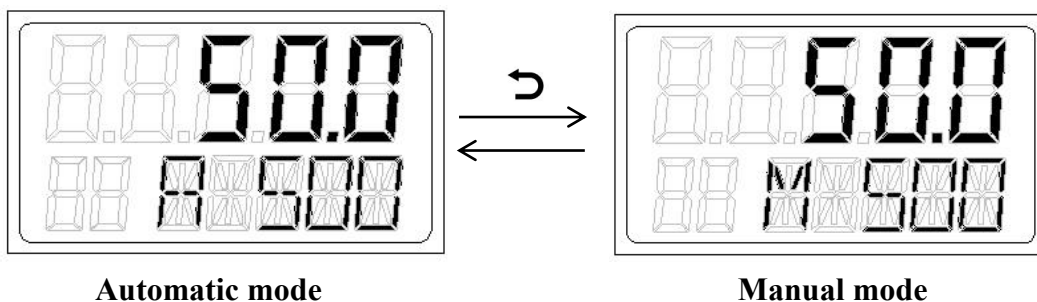

In the main interface, the top line shows the valve position percentage value, and the bottom line shows the set-point percentage value. The last digit of the set-point percentage value is one decimal place. Sign **A** means automatic mode and sign **M** means manual mode. They can be switched by pressing \supset button. If the release time after pressing the \supset button is less than the operation time of entering the menu, operating mode can be switched. Otherwise, it will enter the menu.



Automatic mode

Manual mode



Figure 24. Operating mode interface

PST (partial stroke test) function can be executed in the automatic mode. Press and hold  button for approx. 3s to switch to the PST operation interface. Press  button to exit to the automatic mode interface. In the PST operation interface, if the PST function is not enabled, the first line of the interface will display **oFF**. If the PST function is enabled, when the absolute difference between the valve position and the starting position is within the tolerance range of the starting position and the PST parameter configuration is correct, Press and hold  button for approx. 3s to execute the PST function. The actuator moves from the starting position to the upper or lower limit of the target position according to the PST parameters. If the PST function is successfully executed, the interface will be display **SUCS**. If the PST function fails to execute, the interface will display **FAIL**. When executing PST function, the execution can be interrupted by pressing  button. If the PST function does not meet the execution conditions, the following error code will be displayed.

Error code	Description
Err 1	The absolute difference between the valve position and the starting position is not within the tolerance range of the starting position.
Err 2	PST parameter configuration error. The upper limit of the target position must be $\leq 99\%$, and the lower limit of the target position must be $\geq 1\%$.

8.3. Menu and functions

8.3.1. Display and operation of menu

Press and hold  button for approx. 3s to enter the menu. Press  button, it will exit from menu interface to manual mode interface. The positioner with HART function cannot modify parameters or perform initialization operation through HART communication in the menu interface.

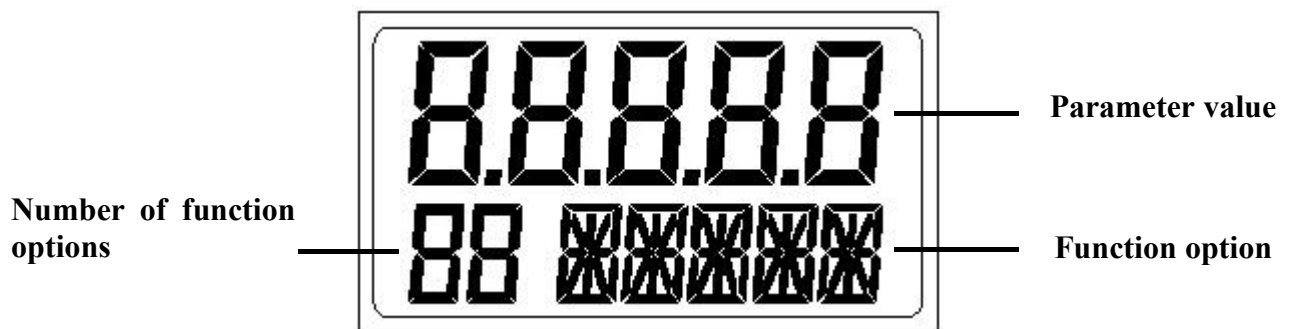

Figure 25. Menu interface

8.3.2. Functions description and operation

8.3.2.1. TYPE

TYPE is for setting the actuator type.

Options for setting parameter

Option	Description
Lin	Linear actuator.
Turn	Rotary actuator.

Select this function in the menu interface, press button to start setting parameters, and the parameter will flash. Press buttons to set parameter and press button to confirm.

8.3.2.2. INITA

The function is auto initialization. It will automatically detect action direction, actual physical stroke of valve and control parameters.

Select this function in the menu interface, press and hold button for approx. 3s to run, a scroll sign will appear in the lower left corner of LCD. Top line shows the percentage value of sensor and the step is showed in the bottom line. Sign **FINSH** will display on LCD after the auto initialization is completed.

For some reasons, the system will display an error message in the function option line during the auto initialization process and the auto initialization will be interrupted. Descriptions of error messages and solutions are showed in chapter 8.3.3.

8.3.2.3. INITM

The function is manual initialization. It is suitable for the user to confirm the valve stroke manually. The function requires the user to calibrate the valve stroke manually. Then it will automatically detect action direction and control parameters. The operation flow is as follows:

- 1) Select this function in the menu interface, press and hold button for approx. 3s to run, a scroll sign will appear in the lower left corner of LCD. Top line shows the percentage value of sensor and bottom line shows **END 1**.
- 2) When LCD displays **END 1**, press buttons to let the valve position move to the endpoint 1 of the manual calibrating stroke, and press button to confirm, then LCD will display **END 2**. Next, press buttons again to let the valve position move to the endpoint 2 of the manual calibrating stroke, and press button to confirm.
- 3) If there isn't error message after confirmation of **END 2**, the system will run the step 1 of initialization automatically and skip step 2 for stroke detection.

LCD will display **FINSH** when manual initialization is completed.

For some reasons, the system will display an error message in the function option line during the manual initialization process and the manual initialization will be interrupted. Descriptions of error messages and solutions are showed in chapter 8.3.3.

8.3.2.4. CAL

CAL is for calibrating 4-20mA input signal. When there is a big deviation between the set point

value and the output value of the signal source, it can be calibrated by this function.

Sub-function options **4mA** and **20mA** are used for calibrating minimum and maximum value of 4-20mA input signal separately.

Select this function in the menu interface, press button to enter sub-function selection operation, and press buttons to select **4mA** or **20mA**, press button to start parameter setting, AD value of actual input signal flashes on LCD (Quantify the set signal numerically, ranging from 0 to 4095). For option **4mA**, set the front-end input signal to 4mA signal; for option **20mA**, set the front-end input signal to 20mA signal. For example, when the front-end input signal is 4mA, value 650 will flash on LCD. After the AD value on LCD is stable, press button to confirm it. The system will record current AD value (650) and it will be displayed on LCD. When the front-end input signal is 20mA, value 3270 will flash on LCD. After the AD value on LCD is stable, press button to confirm it. The system will record current AD value (3270) and it will be displayed on LCD. The calibration of the 4-20mA input signal is completed after the operation of option **4 mA** and option **20 mA**.

For example, if 4-20mA signal is set as 50%(12mA) in the field, while the actual signal value collected by positioner is 52% (12.32mA), it indicates that there is a deviation between the input signal and the signal actually collected by positioner. In this case, calibrate the input signal collected by the positioner by operating as above guidance to make it correspond to 4-20mA signal of the front-end of the system.

8.3.2.5. SDIR

SDIR function sets the corresponding relationship between 4-20mA set-point signal and set-point value.

Select this function in the menu interface, press button to start setting, and the parameter will flash. Press buttons to set parameter and press button to confirm.

Options for setting parameter

Option	Description
riSE	4 mA → 0%, 20 mA → 100%.
FALL	4 mA → 100%, 20 mA → 0%.

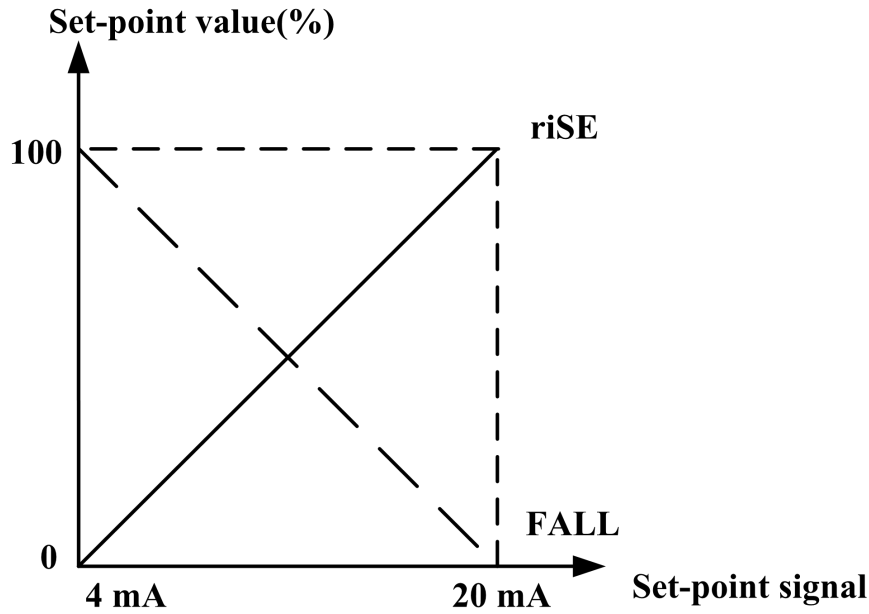

Figure 26. SDIR

8.3.2.6. CHAR

The characteristic curve is the relationship between set-point value and valve stroke.

In the actual control system, it is usually required to make the controlled variable have specific control characteristics (such as linearity). The user can choose and set the corresponding characteristic curve to achieve the control requirements.

The function is to determine the relationship between position set-point value and valve stroke.

Select this function in the menu interface, press button to start setting, and the parameter will flash. Press buttons to set parameter and press button to confirm.

Option for CHAR

Option	Description
Lin	1:1 linear transfer relationship between position set-point value and valve stroke.
1-25	1:25 equal percentage transfer relationship between position set-point value and valve stroke.
1-33	1:33 equal percentage transfer relationship between position set-point value and valve stroke.
1-50	1:50 equal percentage transfer relationship between position set-point value and valve stroke.
n1-25	1:25 inverse equal percentage transfer relationship between position set-point value and valve stroke.
n1-33	1:33 inverse equal percentage transfer relationship between position set-point value and valve stroke.
n1-50	1:50 inverse equal percentage transfer relationship between position set-point value and valve stroke.
FrEE	Freely programmable transfer relationship between position set-point value and valve

stroke for user. The position set-point value scale ranging from 0-100% is divided uniformly into 21 nodes. A freely programmable valve stroke ranging from 0-100% is assigned to each node. User can set value by selecting option **FR 0**, **FR 5**, ..., **FR 100**.

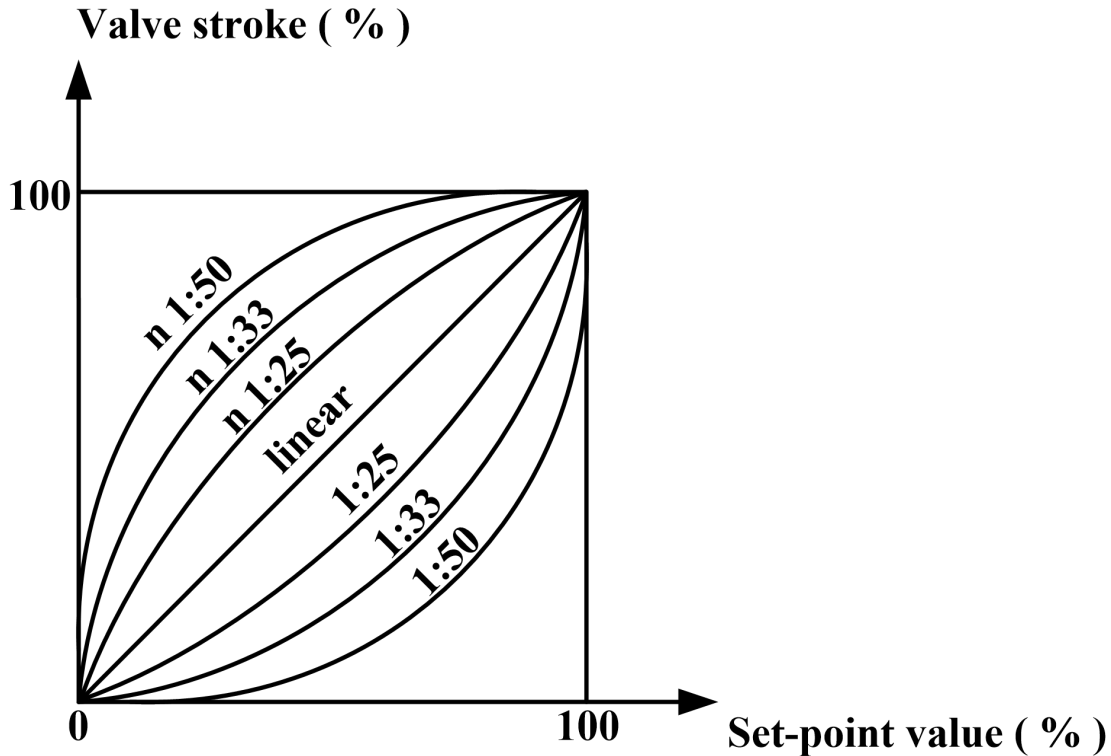

Figure 27. CHAR

8.3.2.7. FREE

Set value of **FrEE** characteristic curve in **CHAR** function option.

Sub-function options of **FREE** are **FR 0**, **FR 5**, ..., **FR 100**, 21 set points in total.

Select this function in the menu interface, press button to enter sub-function option, and select set point by pressing buttons, then press button to start setting parameter, and the parameter will flash. Press buttons to set parameter, it can be modified quickly by pressing or button continuously, finally press button to confirm.

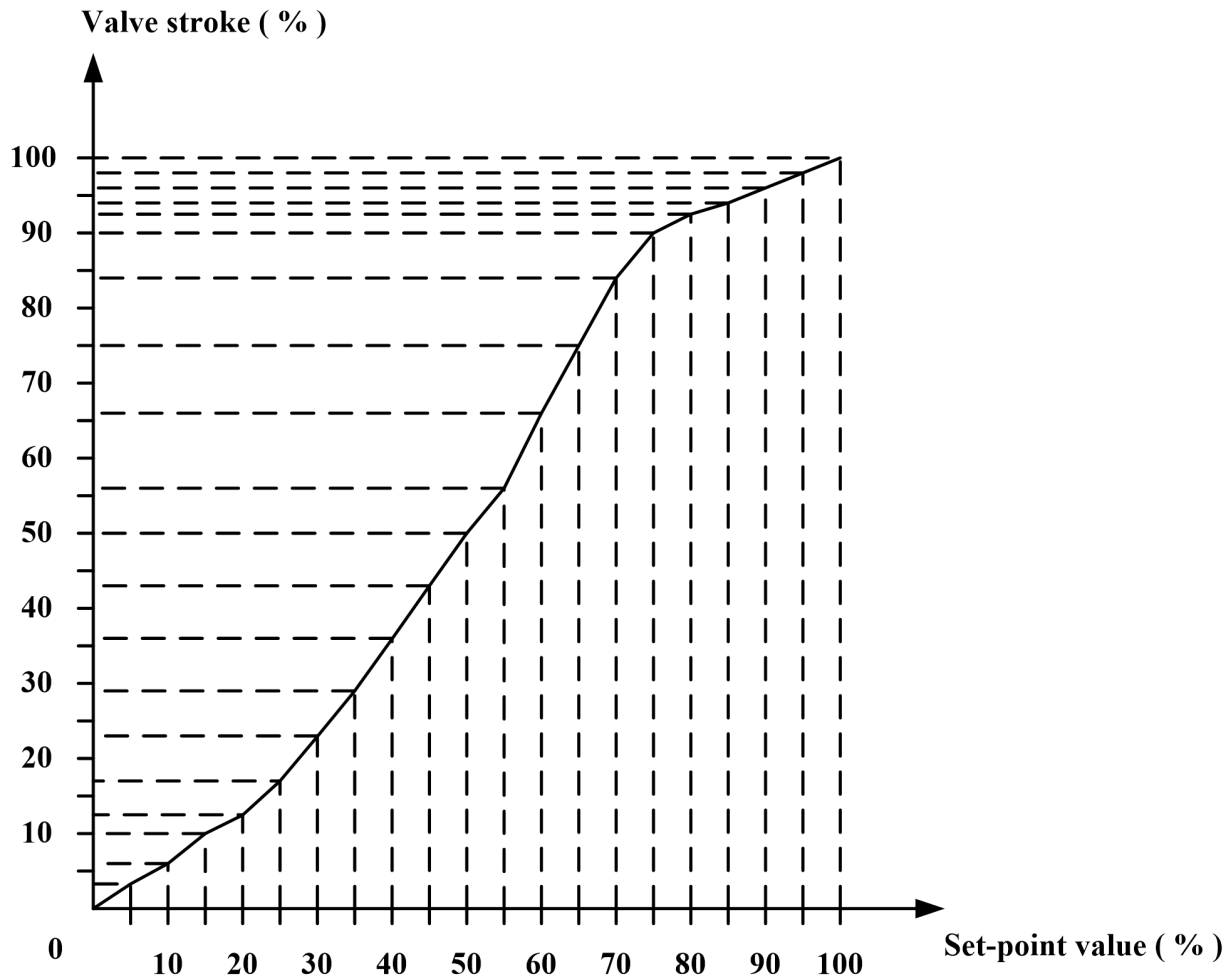

Figure 28. FREE

8.3.2.8. DB

Set Dead band zone of positioner.

The system does not adjust the valve stroke when the gap between the stroke value and the position set-point value is not bigger than the dead band value.

For example, positioner will not do adjustment if the actual valve position is not in the range of $50 \pm 1\%$ when the position set-point value is 50% and dead band value is 1%. If it's not in the range of $50 \pm 1\%$, the piezoelectric module will be driven to adjust valve position until it's in the range of $50 \pm 1\%$.

It's recommended to increase the dead band value if the valve position oscillates. The smaller the dead band sets, the higher control accuracy gets.

Select this function in the menu interface, press button to start setting, and the parameter will flash. Press buttons to set parameter, it can be modified quickly by pressing or button continuously, finally press button to confirm.

8.3.2.9. LIM

This function limits the automatic adjustment range in the whole valve physical stroke.

The LIM sub-function options L MIN and L MAX of set the minimum and maximum limits of the stroke respectively.

Select this function in the menu interface, press button to enter sub-function option, press buttons to select option L MIN or L MAX, press button to start setting, and the parameter will flash. Press buttons to set parameter, it can be modified quickly by pressing or button continuously, finally press button to confirm.

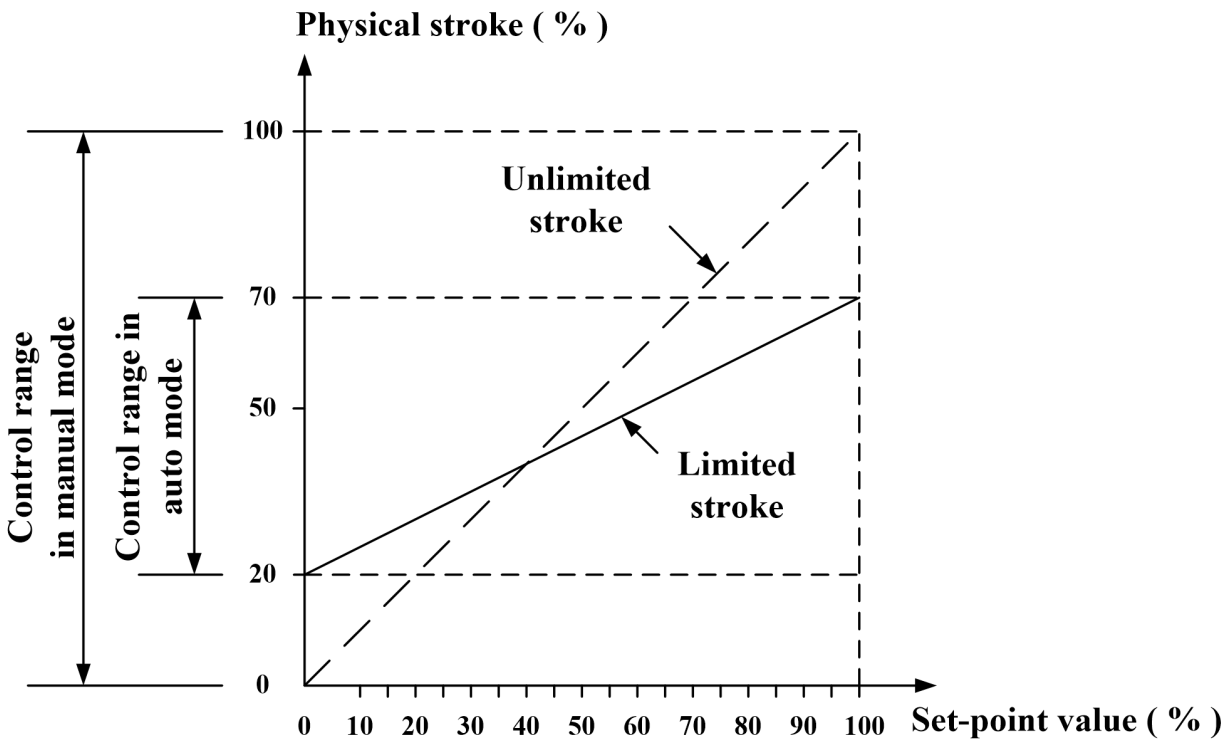

Figure 29. LIM

8.3.2.10. YDIR

This function is used to set the acting direction of the set-point value display, the position value display and position feedback signal output.

Select this function in the menu interface, press button to start setting, and the parameter will flash. Press buttons to set parameter and press button to confirm.

Options for setting parameter

Option	Description
riSE	The setpoint display, position value display, and position feedback signal output are upward trending.
FALL	The setpoint display, position value display, and position feedback signal output are downtrending.

8.3.2.11.CUT

This function is used for the positioner to fully close or open the valve in automatic mode. When the function is enabled, sign **CU** displays in the left bottom in main interface.

The **CUT** sub-function options **C MIN** and **C MAX** respectively set the minimum and maximum values.

Select this function in the menu interface, press \odot button to enter sub-function option, press ∇ \blacktriangle buttons to select option **C MIN** or **C MAX**, press \odot button to start setting, and the parameter will flash. Press ∇ \blacktriangle buttons to set parameter, it can be modified quickly by pressing ∇ or \blacktriangle button continuously, finally press \odot button to confirm.

When **C MIN** value is 0, full closing is disabled. When **C MAX** value is 100, full opening is disabled.

When valve is in the positioning state, if the set point value \leq **C MIN**, the valve will be fully close; if set point value \geq **C MAX**, it will be fully open.

When the set point value $>$ **C MIN** + 1%, valve will disengage from the full closing state.

When the set point value $<$ **C MAX** - 1%, valve will disengage from the full opening state.

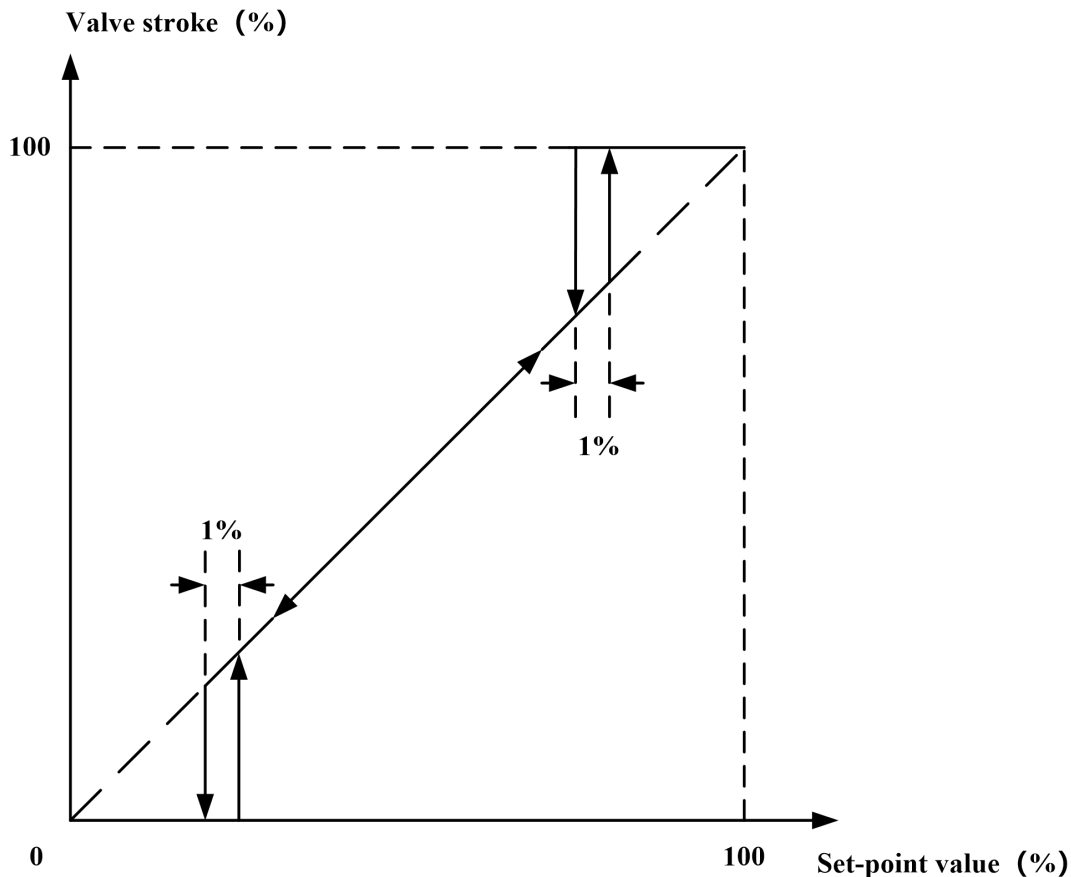

Figure 30. CUT

8.3.2.12.POS

This function is used to set the standard of position display and feedback signal output.

Select this function in the menu interface, press  button to start setting, and the parameter will flash. Press   buttons to set parameter and press  button to confirm.

Options for setting parameter

Option	Description
FS	The position display and feedback signal output correspond to 0-100% of mechanical stroke. The set-point value is displayed as the actual valve position set value. Not affected by the L MIN and L MAX parameters.
LS	The position display and feedback signal output take the form of 0-100% to represent the range between the L MIN and L MAX parameters. The set-point value is displayed with this standard.

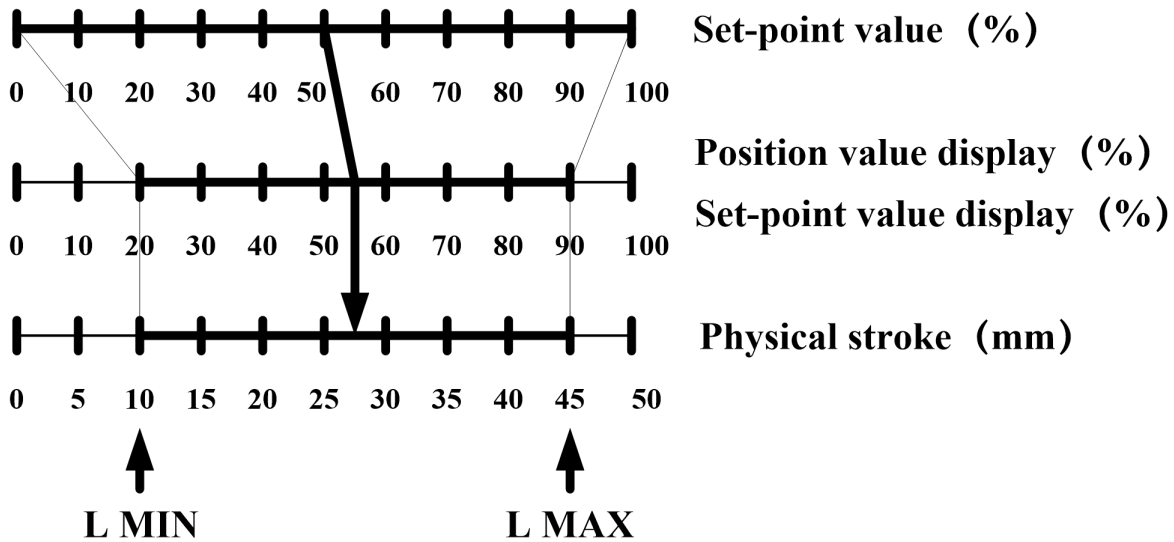

Figure 31. Example: POS = FS, L MIN = 20%, L MAX = 90%

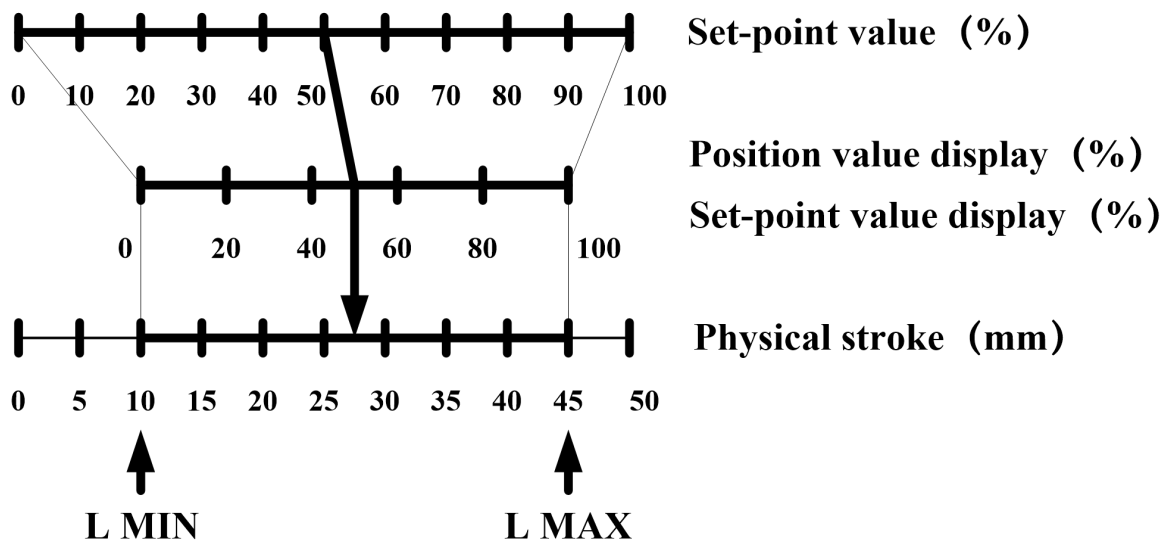



Figure 32. Example: POS = LS, L MIN = 20%, L MAX = 90%

8.3.2.13.FACT

Restore factory settings.

Select this function in the menu interface, press and hold  button for approx. 3s to reset to

factory setting. Then the system is in an uninitialized state and the LCD displays **FINSH**.

8.3.2.14.WP

This function is a parameter write protection function. The parameter **oFF** is write protection disabled, and the parameter **on** is write protection enabled.

Select this function in the menu interface, press button to start setting, and the parameter will flash. Press buttons to set parameter and press button to confirm.

When write protection is enabled, most menu option parameters cannot be modified, and initialization and factory reset functions cannot run.

8.3.2.15.ACT

This function is used to set acting mode. It is used for the manufacturer. It is not recommended for users to operate this option without special circumstances.

8.3.2.16.REC

Record the running data of the positioner. The parameters cannot be restored to factory values by running the **FACT** function.

Options for data recording

Option	Description
HOURS	Running hours count. Start recording after the positioner are powered on.
P CNT	Positive deviation count. In automatic mode, when the positioner is in position control, the position value corresponding to the initialized mechanical stroke is compared with the position set-point value. If the set-point value is greater than the position value, and the deviation between the two exceeds the dead zone value + 10% and lasts for more than 1 minute, the cumulative count is carried out once.
N CNT	Negative deviation count. In automatic mode, when the positioner is in position control, the position value corresponding to the initialized mechanical stroke is compared with the position set-point value. If the position value is greater than the set-point value, and the deviation between the two exceeds the dead zone value + 10% and lasts for more than 1 minute, the cumulative count is carried out once.
CLR	Clear the HOURS, P CNT, N CNT records. Select this option in the submenu of REC, press and hold <input type="button" value="⊙"/> button for approx. 3s to run the function. Then the records are cleared and the LCD displays FINSH .
S/W	Enable or disable the data recording. The parameter oFF is disabled, and the parameter on is enabled.

8.3.2.17.LCD

This function is used to set the LCD display direction. The parameter **uP** is positive direction, and the parameter **do** is reverse direction. The parameter cannot be restored to factory value by running the **FACT** function.

For individual linear valves, if the device needs to be mounted in reverse direction to the valve, this parameter can be set so that the LCD is displayed in a positive direction.

Select this function in the menu interface, press button to start setting, and the parameter will flash. Press buttons to set parameter and press button to confirm.

8.3.2.18.DIAG

Diagnostic parameters. Select this option in the menu interface, press button to enter.

8.3.2.19.1. PST

Partial stroke test parameters. The parameters **STPOS**, **RANGE**, **STEP**, and **DIR** are associated with the stroke of the initialization.

Select the parameter option in the menu interface, press button to start setting, and the parameter will flash. Press buttons to set parameter and press button to confirm.

To perform PST function (partial stroke test), please refer to section 8.2 for details.

Option	Description
S/W	Enable or disable partial stroke test. The parameter oFF is disabled, and the parameter on is enabled.
STPOS	Starting position for partial stroke test.
RANGE	The tolerance range for the starting position. For example, the starting position is 50% with a tolerance range of 2%. Only perform partial stroke test when the valve position is within the range of 48% to 52%.
STEP	Step stroke.
DIR	Stroke direction for partial stroke test. uP : The actuator moves upwards, from the starting position to the upper limit of the target position. do : The actuator moves downwards, from the starting position to the lower limit of the target position. uP do : The actuator moves up and down, first moving from the starting position to the upper limit of the target position. Then move from the upper limit of the target position to the lower limit of the target position. Upper limit of the target position = STPOS + RANGE + STEP . Lower limit of the target position = STPOS - RANGE - STEP .
TIME	Limit time for partial stroke test. Unit: seconds. After starting the partial stroke

test, if the limit time is reached and the actuator has not yet moved to the upper or lower limit of the target position, the test is considered to have failed. Please set this value reasonably based on the actual operating condition of the valve.

8.3.2.19.SPLIT

This function is used for split range control.

The **SPLIT** sub-function options **S MIN** and **S MAX** respectively set the minimum and maximum values. It is recommended that the difference between **S MAX** and **S MIN** should not be less than 30.

Select this function in the menu interface, press button to enter sub-function option, press buttons to select option **S MIN** or **S MAX**, press button to start setting, and the parameter will flash. Press buttons to set parameter, it can be modified quickly by pressing or button continuously, finally press button to confirm.

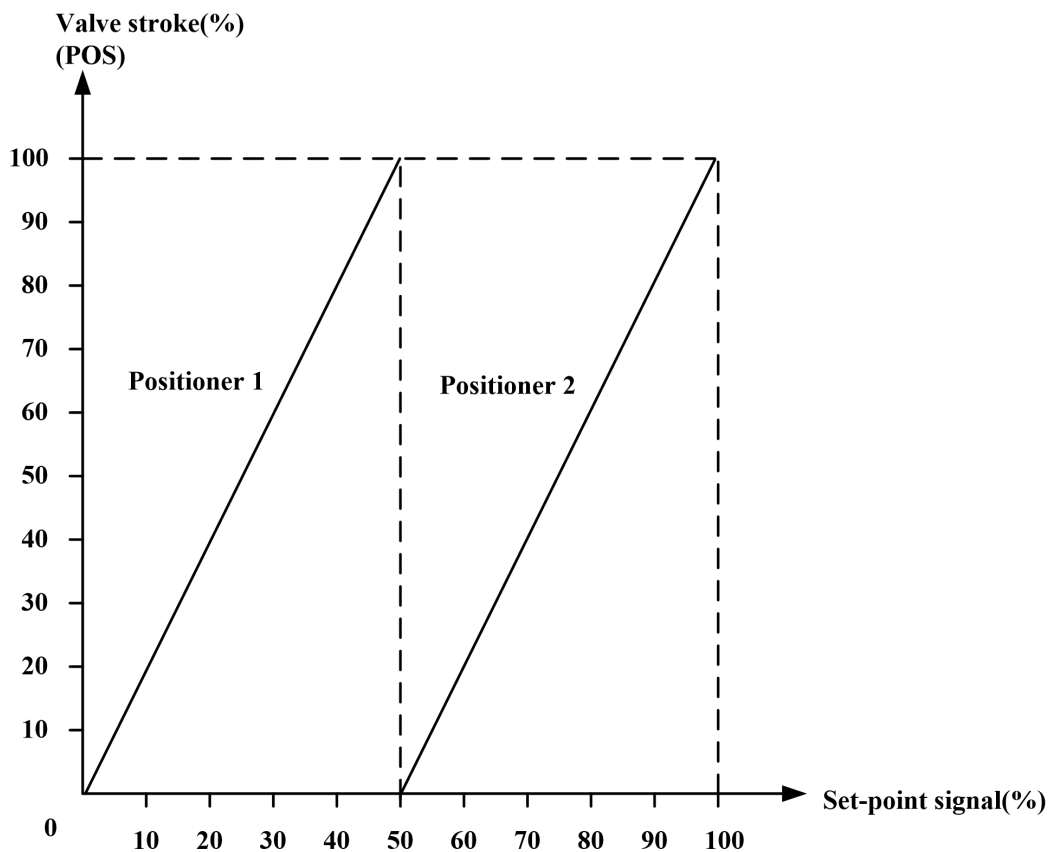

Figure 33. SPLIT

8.3.2.20.EXT

This function is used to optimize the display of position values at 0% and 100% of the stroke endpoint.

When the valve position is at 0% or 100% of the stroke endpoint, the position value displayed on the LCD may not be 0% or 100%. For example, displaying 0.2% at 0% of the stroke endpoint. If the user wants the position value to be displayed as 0%, set this function parameter. When the absolute

value of the difference between the position value and 0% or 100% is less than or equal to the parameter value, the LCD displays 0% or 100%.

Select this function in the menu interface, press button to start setting, and the parameter will flash. Press buttons to set parameter, it can be modified quickly by pressing or button continuously, finally press button to confirm.

8.3.3. Error message during initialization

Sign	Meaning	Possible reasons	Solutions
ERR 1	Actuator action error	<ul style="list-style-type: none"> ● No air pressure or insufficient air pressure ● There is a leakage from actuator or positioner. 	<ul style="list-style-type: none"> ● Check air source and it's pressure to make sure that it meets the requirement ● Eliminate air leakage
ERR 2	Valve stroke does not meet requirements.	<ul style="list-style-type: none"> ● The valve stroke does not match the sensor range. ● The valve stroke is too short. It is below the minimum stroke requirement. ● When running the manual initialization, the difference from END 1 to END 2 doesn't meet the installation requirements. 	<ul style="list-style-type: none"> ● Select the sensor and the valve with appropriate ranges to match. ● If it's in the manual initialization operation process, press <input type="checkbox"/> <input type="checkbox"/> buttons to re-calibrate END 1 and END 2, make sure that difference percentage value between two endpoints of sensor is bigger than 15%.

8.3.4. Tips of menu option or function cannot access

When setting menu option parameters or running initialization, the following signs may appear to indicate that they cannot be accessed. See the table below for specific instructions.

Sign	Meaning
P1	Write protection is enabled.

8.3.5. Menu function options summary description

Options	Functions	Parameter value	Factory settings
1 TYPE	Actuator type setting	Lin Turn	Lin
2 INITA	Auto initialization		
3 INITM	Manual initialization		
4 CAL→4 mA	Calibrate 4mA set point signal	Current signal AD value	800
4 CAL→20 mA	Calibrate 20mA set point signal	Current signal AD value	4000
5 SDIR	Set the direction of set point signal	riSE FALL	riSE
6 CHAR	Select characteristic curve	Lin 1:25 1:33 1:50 n1:25 n1:33 n1:50 FrEE	Lin
7 FREE→FR 0, FR 5...FR 100	Custom parameters settings	0.0% – 100.0%	0.0% 5.0% etc. to 100.0%
8 DB	Set dead band	0.2 – 10.0%	1.0%
9 LIM→L MIN	Set minimum value for stroke range limit function	0.0% – 100.0%	0.0%
9 LIM→L MAX	Set maximum value for stroke range limit function	0.0% – 100.0%	100.0%
10 YDIR	Set the acting direction of position display, set-point display and position feedback signal output	riSE FALL	riSE
11 CUT→C MIN	Set minimum value for tight cut function	0.0% – 100.0%	1.0%
11 CUT→C MAX	Set maximum value for tight cut function	0.0% – 100.0%	100.0%
12 POS	Set Position display and feedback signal output standard	FS LS	FS
13 FACT	Reset to factory setting		

14 WP	Write protection	oFF on	oFF
15 ACT	Acting mode selection		
17 REC→HOURS	Running hours count	0-876000	0
17 REC→P CNT	Positive deviation count	0-99999	0
17 REC→N CNT	Negative deviation count	0-99999	0
17 REC→CLR	Clear data recording		
17 REC→S/W	Enable or disable the data recording	oFF on	on
18 LCD	LCD display direction	uP do	uP
A PST→S/W	Enable or disable PST	oFF on	oFF
A PST→STPOS	PST starting position setting	0.0% – 100.0%	100.0%
A PST→RANGE	PST starting position tolerance range setting	0.2% – 10.0%	2.0%
A PST→STEP	PST step stroke Setting	1.0% – 98.8%	10.0%
A PST→DIR	PST stroke direction setting	uP do uPdo	do
A PST→TIME	PST limit time setting	1s – 100s	50s
20 SPLIT→S MIN	Set minimum value for split range control function	0.0% – 70.0%	0.0%
20 SPLIT→S MAX	Set maximum value for split range control function	30.0% – 100.0%	100.0%
21 EXT	Optimization display of stroke endpoint position value	0.0% – 10.0%	0.0%

8.4. HART DD file and DTM file description

8.4.1. Device dynamic variable description

Dynamic variable	Description
PV	Position setpoint percentage value
SV	Position percentage value

8.4.2. Device custom function description

The device custom function is in the **Detailed setup** directory of the DD file and DTM file. The function options and descriptions are shown in the following table:

Options	Description
TYPE	See chapter 8.3.2.1 for details.
INIT	Automatic initialization start or stop, initialization status indication. For the initialization function, please refer to Chapter 8.3.2.2 and Chapter 8.3.2.3.
SDIR	See chapter 8.3.2.5 for details.
CHAR	See chapter 8.3.2.6 for details.
FREE	See chapter 8.3.2.7 for details.
DB	See chapter 8.3.2.8 for details.
LIM	See chapter 8.3.2.9 for details.
YDIR	See chapter 8.3.2.10 for details.
CUT	See chapter 8.3.2.11 for details.
POS	See chapter 8.3.2.12 for details.
FACT	See chapter 8.3.2.13 for details.
REC	See chapter 8.3.2.16 for details.
Setpoint	Setpoint value setting.
Status	System status indication.
DIAG→PST	See chapter 8.3.2.19.1 for details.

The options and descriptions in the **INIT** directory are shown in the following table:

Options	Description
INIT status	Initialization status indication.
INIT start	Automatic initialization starts.
INIT stop	Automatic initialization stops.

INIT status signs and descriptions are shown in the following table:

Signs	Description
NOINI	Uninitialized.
FINSH	Initialization finish.
STEP1, STEP2, STEP3	Initialization steps.
ERR 1, ERR 2, ERR 3, ERR 4	Initialization error message.

The options and descriptions in the **Setpoint** directory are shown in the following table:

Options	Description
PV	Device dynamic variable.
SV	Device dynamic variable.
Setpoint source	Set the setpoint source. Can be set to 4-20mA or HART , the default is 4-20mA . When set to 4-20mA , the setpoint value is determined by the external 4-20mA signal. When set to HART , the setpoint value is determined by the input value from HART communication. The HART Setpoint input option is jumped out from the directory. It is used to enter the setpoint value.
HART Setpoint input	Enter the setpoint value if Setpoint source is set to HART .

The options and descriptions in the **Status** directory are shown in the following table:

Options	Description
Working status	System working status.
Cutoff status	Cutoff status in automatic mode.

Working status signs and descriptions are shown in the following table:

Signs	Description
NOINI	The system is not initialized.
Config mode	The system is in menu configuration mode or performing initialization.
Auto mode	The system is in automatic mode.
Manu mode	The system is in manual mode.

Cutoff status signs and descriptions are shown in the following table:

Signs	Description
No	The system is not in cutoff status.
Cutoff down	Cutoff status corresponds to C MIN .
Cutoff up	Cutoff status corresponds to C MAX .

The options and descriptions in the **DIAG→PST** directory are shown in the following table:

Options	Description
Parameters	PST parameters.
Test	Operate PST.

The options and descriptions in the **PST→Test** directory are shown in the following table:

Options	Description
PST start	Start PST.
PST stop	Stop PST.
PST status	PST status indication.

PST status signs and descriptions are shown in the following table:

Signs	Description
Not running	PST is not running.
Running	PST is running.
SUCS	PST is successful.
FAIL	PST is failed.

8.5. Feedback signal

The positioner can be optionally equipped with a 4-20 mA feedback signal. It indicates the percentage value of the valve position.

The feedback signal module is based on a two-wire system, it needs 24V DC power supply. The feedback signal will stop updating after entering the menu.

8.6. Adjust air flow

1. Remove the circuit board protective cover.

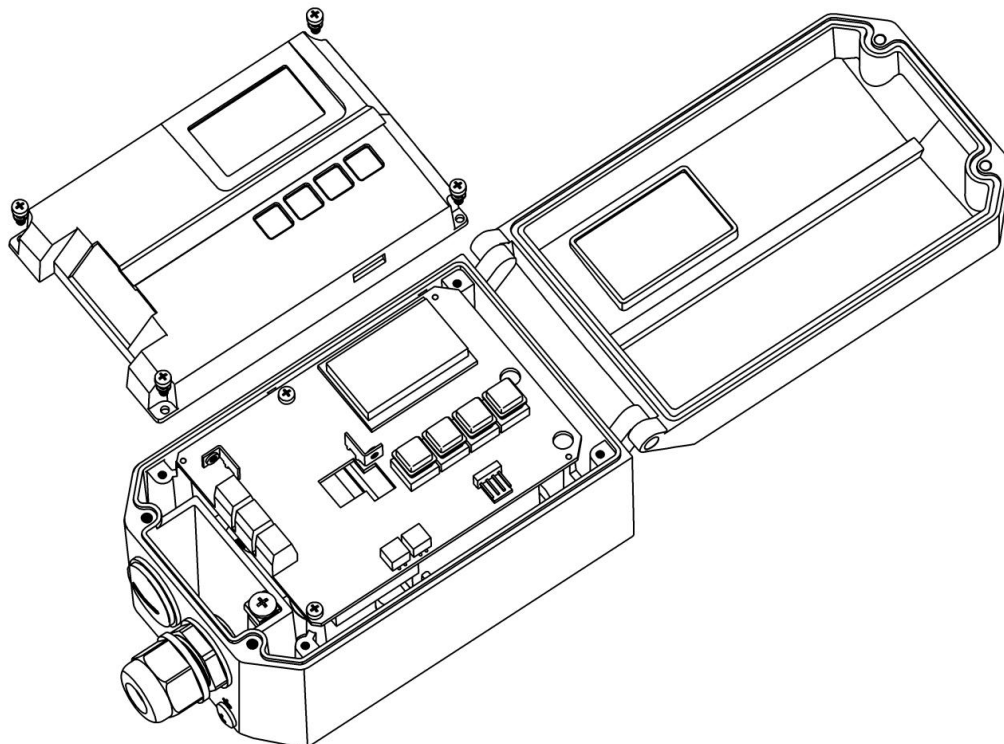

Figure 34. Remove the circuit board protective cover

NOTE: Must install or remove the circuit board protective cover when the device is powered off.

2. Adjust restrictors

- Restrictors Y1 ① and Y2 ② can reduce air output to increase the stability of positioning for small volume actuators.
- Turning the Restrictors in clockwise direction with a flat blade screwdriver can reduce the air flow until it is cut off.
- When adjusting restrictors, it is recommended to close them first and then open them again slowly.
- Make sure two restrictors are turned to the similar position for the double-acting actuator.

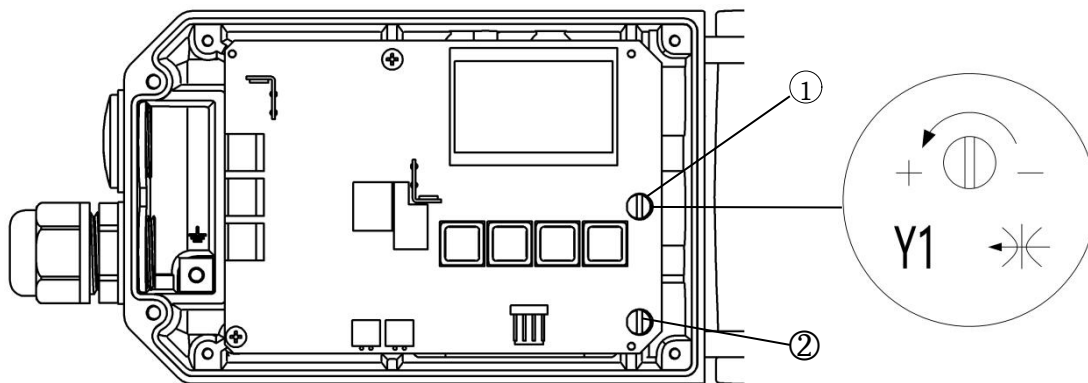

Figure 35. Air flow adjustment

- ① Restrictors Y1
- ② Restrictors Y2, only for double-acting actuator.

9. Trouble shooting

Contents	Possible reasons	Solutions
LCD has no display	Error electrical connections.	Check the electrical connections
	No current output from current source	Make sure that there is current output from the current source.
	The current source is out of specified range	Use the proper current source.
	Others	Consult with manufacturer.
There is no air output in OUT1 or OUT2 (Without any action)	The air supply pressure is abnormal	Check the setting of the air pressure reducing valve.
	No input current	Make sure the input current is proper. (4-20mA DC)
	Accessory pipe leakage	Check the pipe and connection to make sure that there isn't any leakage.
	Others	Consult with manufacturer.
Bad accuracy (Linear and hysteresis phenomena)	The air supply pressure changes	Check whether there is any abnormality of the air supply pressure reducing valve
	The mounting bolts loose	Make sure the mounting bolts are tightened.
	The connection place between the positioner and the actuator has gap	Check the connection.
	Set-point value deviation	Adjust the current output signal.
		Calibrate the set-point signal.
Others	Consult with manufacturer.	

10. Warranty terms

1. If the product is found to have quality problems which are confirmed by our company staff, customers have after-sale services for product maintenance or free replacement in the warranty period. Service response time is 24 hours (excluding non-working days).
2. The warranty period of the product is based on the company's latest warranty policy, which is no less than 12 months after the sale.
3. The following situations for repaired product do not belong to the warranty range:
 - (1) The date is not in the warranty period.
 - (2) The product is disassembled without authorization and permit by the product company.
 - (3) The damage causes from the operation which is not according to the product instruction manual or other human factors. Including but not limited to:
 - 1> The product surface has collision scars.
 - 2> Error wiring or error power supply makes the product damaged.
 - 3> Parts and accessories are lost.
 - 4> The product is damaged due to the oil entering the product without oil separator or filter pressure reducer being installed.
 - 5> Error using the waterproof electrical connectors makes the product damaged.
 - 6> Plugging or removing the vent plug without permission.
 - (4) Force majeure (natural disasters) causes product failure or damage.
4. According to the actual situation, the product company offers the free or fee-based maintenance services outside the warranty range.
5. The terms become effective since the two sides signed a supply contract.

V260414

本说明书内容变更，恕不另行通知。

相关技术更新本公司保留最终解释权。

The changed contents of this manual are not noticed.

The Company reserves the final interpretation for related technical updating

附件

智能阀门定位器气源要求

全系列产品

按照技术要求，全系列的智能阀门定位器气源要求为 3 级，提供符合气源要求的压缩空气，可以确保定位器的正常使用。

露点 3 级：露点为 -20°C 。（若定位器实际工作环境温度低于 -20°C ，则使用的压缩空气露点需

相应低于定位器实际工作环境温度 -10°C ）

固体颗粒大小和密度 3 级： $5.0\text{mg}/\text{m}^3$ （对应粒径为 $5.0\mu\text{m}$ ），不允许有粒径大于 $5.0\mu\text{m}$ 的颗粒进入。

含油量 3 级： $1.0\text{mg}/\text{m}^3$ ，每单位立方米的空气累积油含量不超过 1.0mg 。

流程示例



图 1. 流程图

①在主管路中配备压缩空气干燥机，过滤掉压缩空气中产生的大部分水分，过滤后的压力露点可达到 -20°C ；

②选择任意与图 2 一致的调压过滤器组合安装在定位器管路的前端，安装时需过滤减压阀（空气过滤器）在前，油雾分离器在后，要求过滤器过滤粒径在 $5.0\mu\text{m}$ 以上的颗粒，最高残余油含量 $\leq 1.0\text{mg}/\text{m}^3$ 。

过滤减压阀 + 油雾分离器

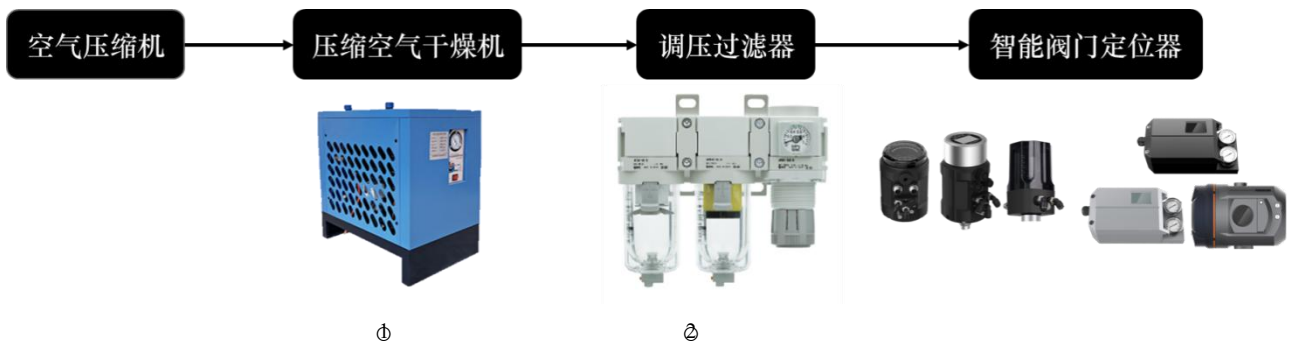
AW

AFM



AC20D-A~AC40D-A 系列

空气过滤器 + 油雾分离器 + 减压阀

AF

AFM

AR



AC20C-A~AC40C-A 系列

图 2. 调压过滤器组合

过滤器选型推荐

选型组合	<p>空气过滤器 + 油雾分离器 + 减压阀</p> <p>AF AFM AR</p>	<p>过滤减压阀 + 油雾分离器</p> <p>AW AFM</p>
	<p>AC 30 C- 03 DG- - -A</p> <p style="text-align: center;"> 1 2 3 4 5 6 </p>	<p>AC 30 D- 03 DG- - -A</p> <p style="text-align: center;"> 1 2 3 4 5 6 </p>
选型编号	SMC AC20C-02G-A	SMC AC20D-02G-A
	入口侧压缩空气质量略低于定位器使用要求时	入口侧压缩空气质量符合定位器使用要求时
基础参数	流体：空气	

	环境温度及使用温度：-5~60°C（未冻结） 耐压：1.5MPa 使用压力范围：0.05~1.0MPa 设定压力范围：0.05~0.7MPa 过滤精度：AW:5um、AFM：0.3um（捕集效率 99.9%） 杯体材质：聚碳酸酯 结构：溢流型		
选型参数	①主体尺寸：20 额定流量：200L/min 杯体保护罩：标准（钢带） 质量：0.39kg ②螺纹种类（无记号）：Rc ③接口管径 O2：1/4 ④无记号：手动排水器 压力表 G：圆形压力表（带限位指示器） ⑤无记号：无附件 ⑥无记号：无特殊选择	①主体尺寸：20 额定流量： 150L/min 杯体保护罩：标准 （钢带） 质量：0.33kg	①主体尺寸：30 额定流量： 330L/min 杯体保护罩：标准 装备（聚碳酸酯） 质量：0.66kg
		②螺纹种类（无记号）：Rc ③接口管径 O2：1/4 ④无记号：手动排水器 压力表 G：圆形压力表（带限位指示器） ⑤无记号：无附件 ⑥无记号：无特殊选择	
1 系列定位器*	●	●	/
IP 系列定位器*	●	/	●

*●为推荐的选择

注：过滤器处理空气额定流量需大于定位器的最大工作流量，在同一串联管路上存在多台定位器时则最大工作流量需相加计算（1 系列最大流量 1500、1600：Q1-17L/min；Q2-95L/min；1880S：17L/min IP 系列最大流量 IP5500: 155 L/min；IP6000/IP6500/IP7000:187 L/min；IP6000d: 150 L/min 以上数据均为 0.6MPa 下测量所得）。

注意事项

1. 应视工况要求选择不同性能的调压过滤器，避免因工作环境的高温、低温、高压、腐蚀等原因导致调压过滤器失效,详见末尾附录选型表。
2. 定期巡查过滤器的使用情况，若使用频繁的工况应提高巡查次数，避免因过滤器滤芯堵塞导致的故障问题（故障举例：①过滤失效，导致定位器进入异物，致使定位器故障；②滤芯堵塞，导致气源供应异常，定位器无法正常工作等）。
3. 采用自动排水功能的调压过滤器需要避免排水孔的堵塞，定期巡查可避免过滤器故障导致滤杯内大量积水。手动排水的应视工况下过滤器的积水速率，定时人工排水。
4. 按照调压过滤器的使用说明，定期维护或更换不合格的产品，可避免不必要的故障出现。