

IP7000系列 智能阀门定位器

IP7000 Series Intelligent Valve Positioner
Brief Introduction

简要介绍

01

技术描述

Technical Description



IP7000系列智能阀门定位器

IP7000系列智能阀门定位器和气动调节阀配套使用。通过接收来自控制系统的4-20mA DC电流信号得到阀位控制设定值，同时采集位置传感器信号得到实际的阀位值，两者通过控制软件的计算处理，从而控制气动执行机构的进气和排气，驱动阀位到达设定点。

外壳材质

- 铝合金、喷塑

压力表组件

- 铝、阳极氧化

信号输入

- 电流：4-20mA DC
- 空载电压：15-24V DC
- 输入阻抗：120Ω

输出信号

- 二线制4-20mA信号

数字通讯协议

- HART 7

最小工作电流

- 3.8mA

稳态耗气量

- ≤ 0.4 L/min

行程范围

- 常规型直行程：10-110mm
- 常规型角行程：80-100°

气动数据

- 空气质量：符合 ISO 8573-1 标准
- 压力：1.4-7bar (20.3-101.5 psi)
- 固体颗粒大小和密度：等级3
- 压力露点：等级3（最低比环境温度低20K (36° F)）
- 含油量：等级3

> 流量

- 进气:

| | |
|-------|-------------------------|
| 2 bar | 4.8 Nm ³ /h |
| 4 bar | 8.0 Nm ³ /h |
| 6 bar | 11.2 Nm ³ /h |
- 排气 (复位) :

| | |
|-------|-------------------------|
| 2 bar | 5.9 Nm ³ /h |
| 4 bar | 9.8 Nm ³ /h |
| 6 bar | 13.7 Nm ³ /h |
- 排气 (保位) :

| | |
|-------|-------------------------|
| 2 bar | 6.6 Nm ³ /h |
| 4 bar | 11.1 Nm ³ /h |
| 6 bar | 15.6 Nm ³ /h |

> 电气接口

- NPT 1/2 (默认)
- M20 × 1.5

> 气动接口

- NPT 1/4 (默认)
- G 1/4

> 防护等级

- IP69K

> 抗震动性

- 0.15 mm, 10Hz-60Hz, 20次循环/轴
- 20 m/s², 60Hz-500Hz, 20次循环/轴
- 整个控制阀连续运行时的推荐范围 ≤ 20 m/s², 无谐振峰值

> 线性度及回差

- 线性度: ≤ 1.0 %
- 回差: ≤ 1.0 %

> 环境温度

- 非防爆常规版本:
 - 20°C ~ + 80°C
- 非防爆低温版本:
 - 40°C ~ + 80°C
- 本安防爆常规版本:
 - 20°C ~ + 80°C (T4/T200 135°C)
 - 20°C ~ + 40°C (T6/T₂₀₀ 85°C)
- 本安防爆低温版本:
 - 40°C ~ + 80°C (T4/T200 135°C)
 - 40°C ~ + 40°C (T6/T₂₀₀ 85°C)

> 防爆等级域

- 本安:
 - Ex ia II C T4/T6 Ga
 - Ex ia III C T₂₀₀ 135°C/T₂₀₀ 85°C Da

› 本安防爆型电气参数

| 回路名称 | 最高输入电压 | 最大输入电流 | 最大输入功率 | 最大内部等效参数 | |
|-----------|--------------------|---------------------|--------------------|---------------------|---------------------|
| | U _i (v) | I _i (mA) | P _i (W) | C _i (nF) | L _i (mH) |
| 4-20mA 设定 | 28 | 93 | 0.66 | 近似为0 | 近似为0 |
| 4-20mA 输出 | 28 | 93 | 0.66 | 近似为0 | 近似为0 |

› 电磁兼容性结果摘要

| 测试对象 | 测试项目描述 | 基本标准 | 测试级别 | 检测结果 |
|------|-------------|--------------|---------------------------------------|------|
| 本安型 | 静电放电抗扰度 | GB/T 17626.2 | ± 4kV 触点 ± 8Kv 空气 | 通过 |
| 本安型 | 射频电磁场辐射抗扰度 | GB/T 17626.3 | 3V/m, 80%AM (1kHz) , 80MHz-1000MHz | 通过 |
| 本安型 | 工频磁场抗扰度 | GB/T 17626.8 | 50Hz, 100A/m | 通过 |
| 本安型 | 电快速瞬变脉冲群抗扰度 | GB/T 17626.4 | ± 1.0 kV | 通过 |

› 额定条件 - 高度

- 海平面以上2000m
- 在海拔2000m以上的位置，请使用合适的电源

› 额定条件 - 安装位置

- 任意
- 在潮湿环境中，气动接头和排气口不朝上，正确安装

> 位置反馈模块

用于位置反馈直流输出，2线制连接

| | |
|--------------------------|--|
| 电流输出 | 端子OUT1和OUT2 |
| 输出额定信号范围 | 4-20mA，防短路 |
| 动态范围 | 3.8-20.5mA |
| 外部负载 R_B [k Ω] | $\leq (U_{Aux}[v]-12v) I$ [mA] |
| 传动误差 | $\leq 0.5\%$ |
| 温度影响 | $\leq 0.1\%/10K$ ($\leq 0.1\%/18^\circ F$) |
| 分辨率 | $\leq 0.1\%$ |
| 有效内部电容 | C_i =近似为零 |
| 有效内部电感 | L_i =近似为零 |

02

优点及应用

Advantages & Applications

> 优点

- 安装简单，一键初始化
- 德国原装进口，成熟可靠的压电式气动模块
- 操作简便，使用4个按键和LCD进行本地操作
- 多种菜单功能配置。如特性曲线，行程限制等
- 稳态工作耗气量可忽略不计
- 紧密关闭功能
- 保位功能（根据产品选型选择）
- 直行程和角行程执行机构采用同一型号的定位器
- 抗震性好
- 可对 4-20 mA 输入信号进行现场校正
- 非接触式位移传感器

> 应用

- 炼油/石化/核电/电厂
- 造纸和玻璃/水和污染
- 食品和制药
- 海上平台

03

机械尺寸

Mechanical Dimensions

> IP7000定位器机械尺寸

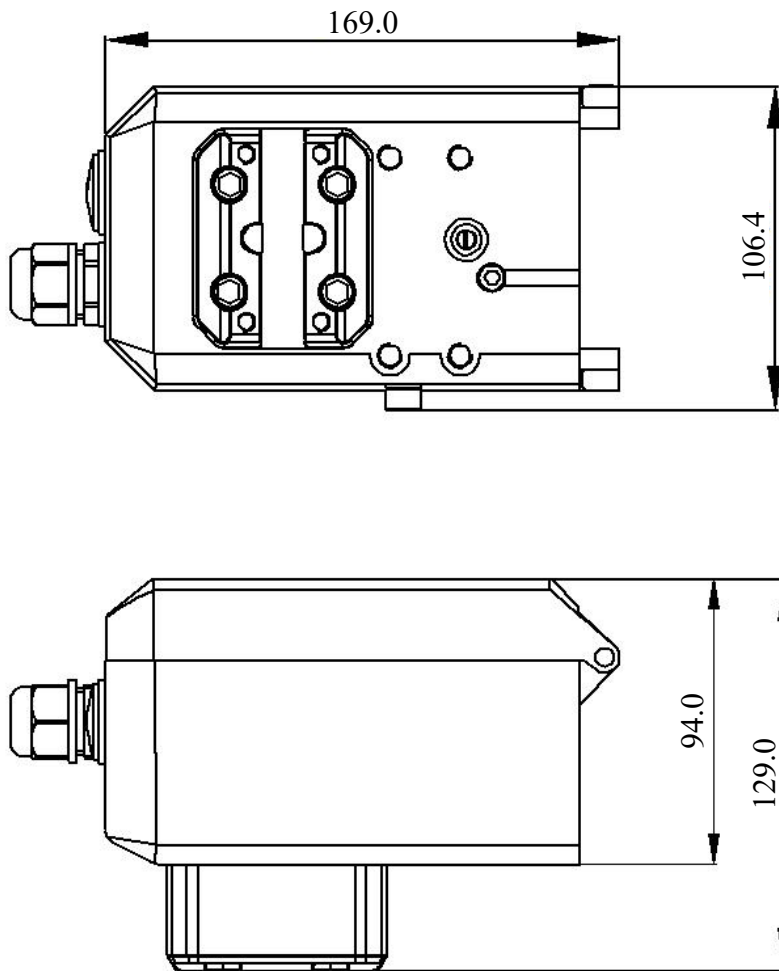

› 25mm磁条（可用于行程10-25mm）

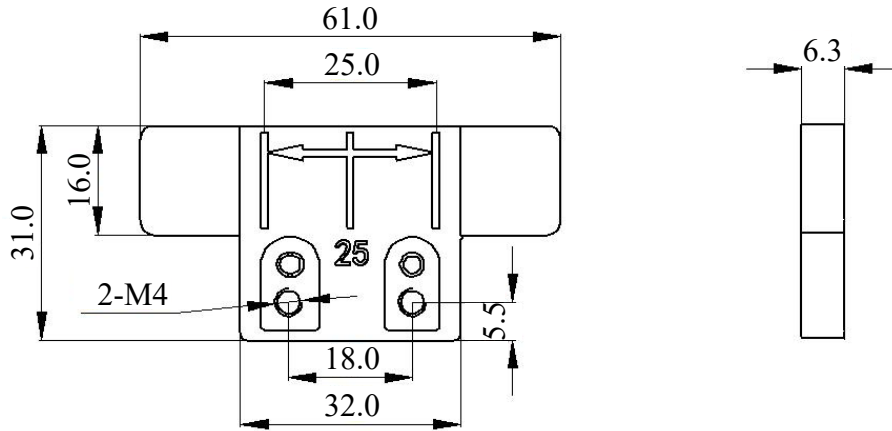

› 38mm磁条（可用于行程25-38mm）

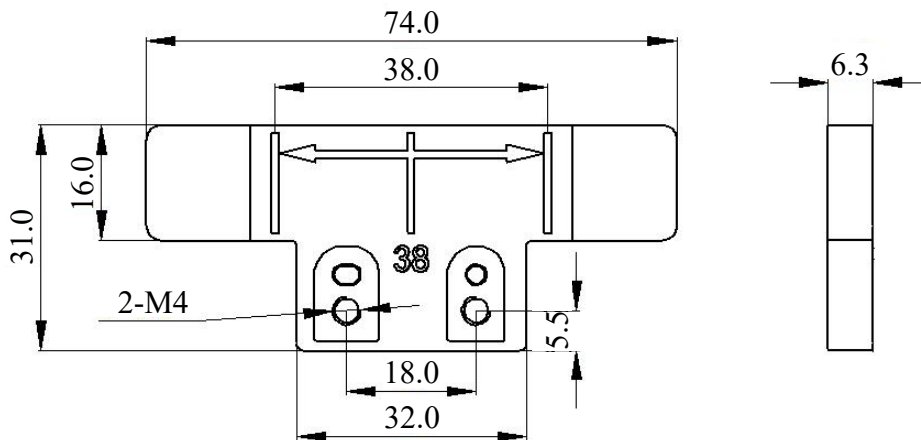

› 50mm磁条（可用于行程38-50mm）

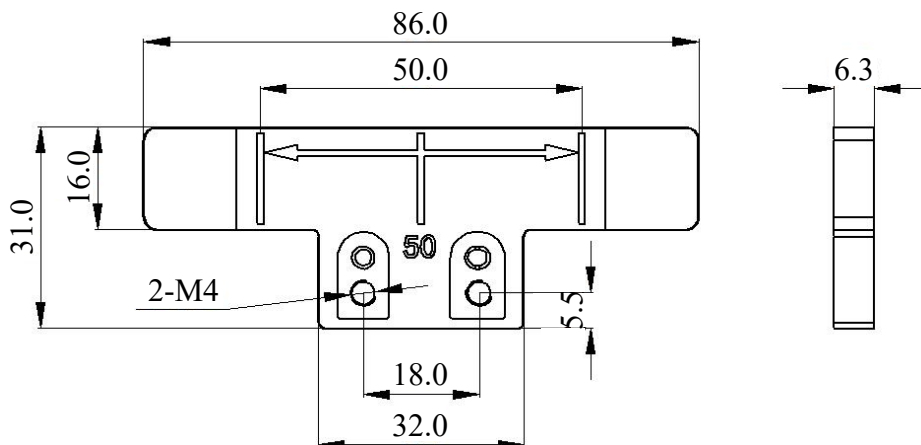

› 110mm磁条（可用于行程50-110mm）

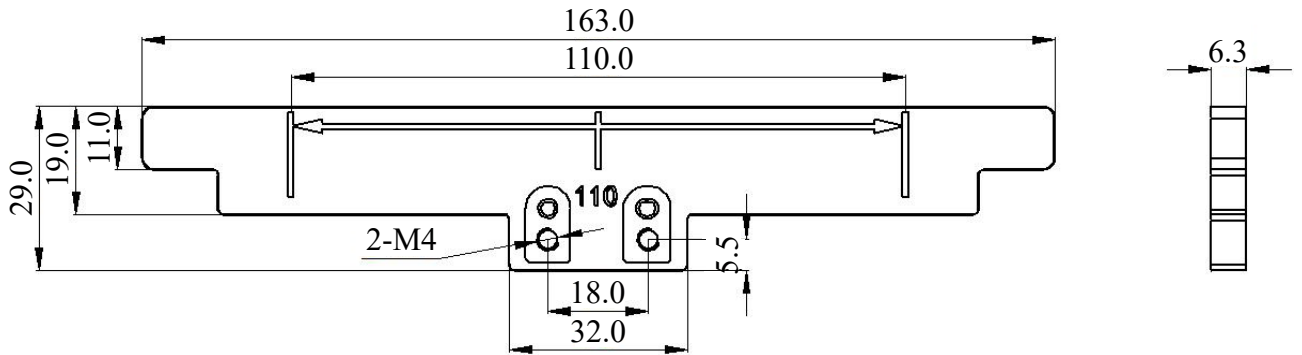

› 角行程磁条外形图

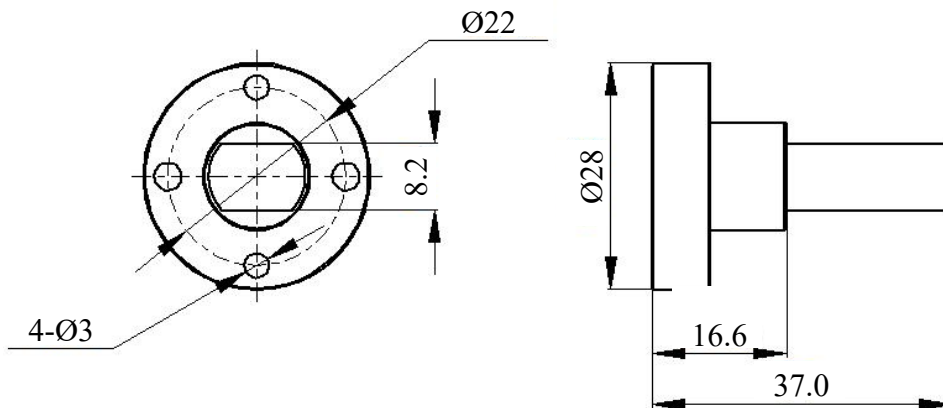

› 角行程磁条连接件

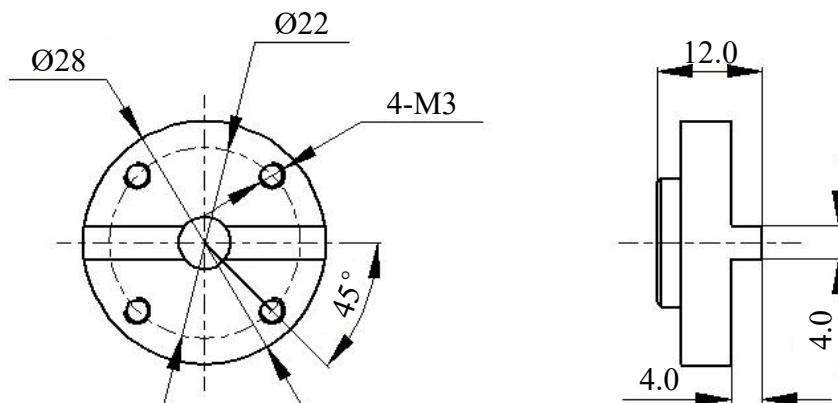

› 直行程安装支架组装形式

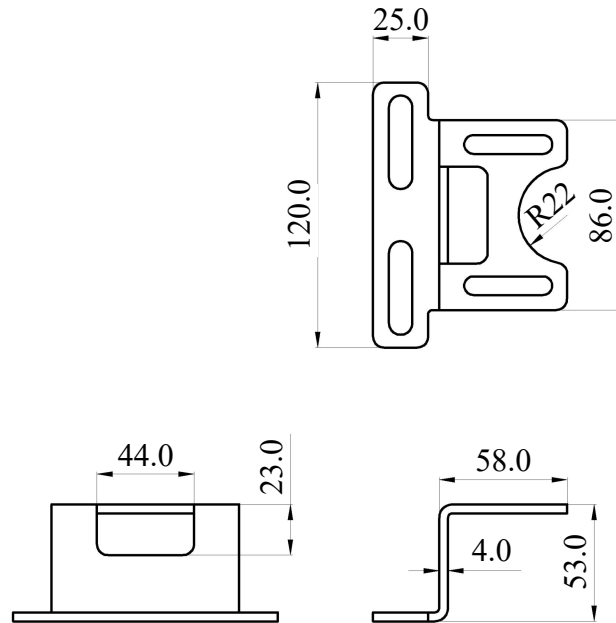

› 角行程安装支架组装形式-1

› 角行程安装支架组装形式-2

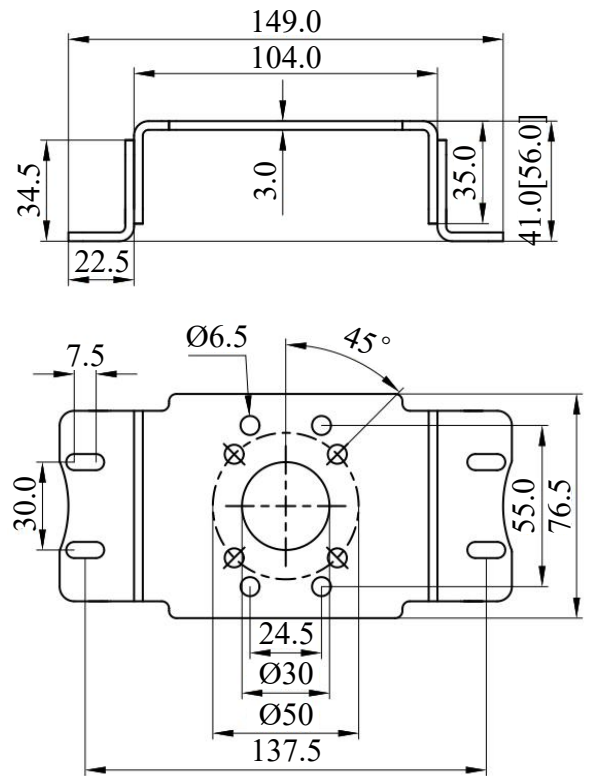
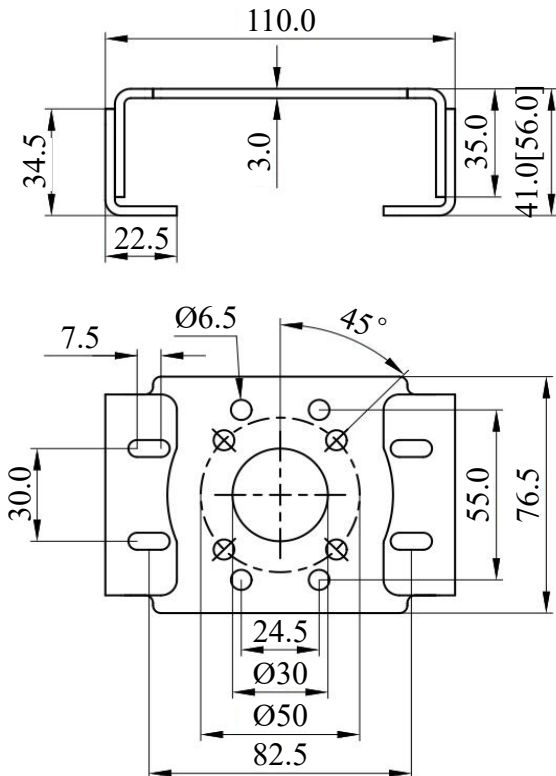

04

产品结构

Product Structure

> IP7000定位器产品结构

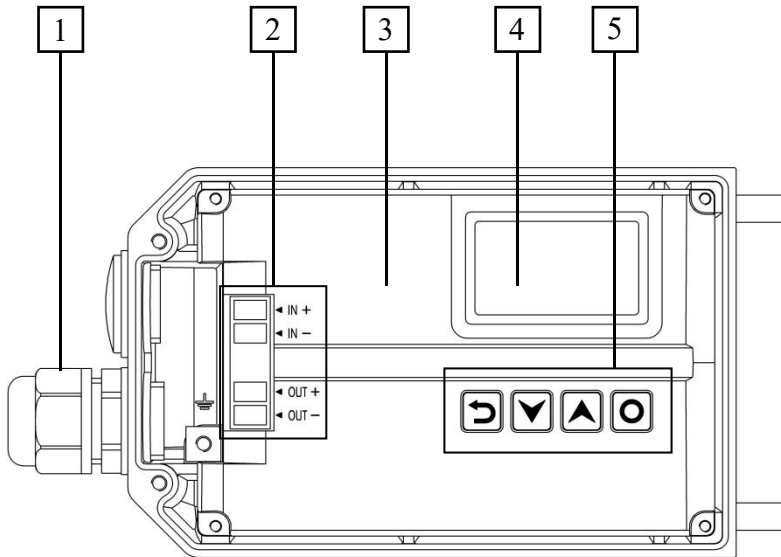

- 1 电气线缆接入
- 2 电气接线位置
- 3 保护盖
- 4 液晶显示
- 5 按键

05

电气接口、气动接口及接线图

Electrical & Pneumatic Connections, Wiring Diagram

> 电气接口

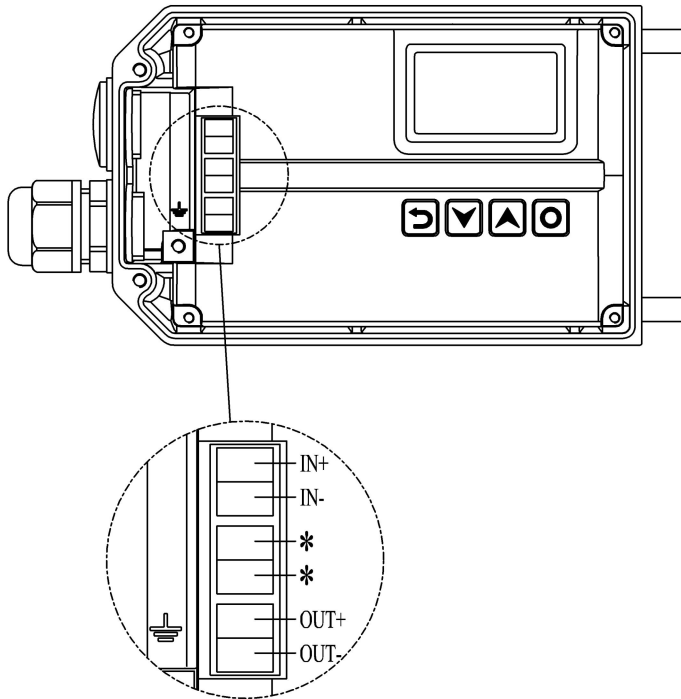

- IN+: 4-20 mA 设定信号 +
- IN-: 4-20 mA 设定信号 -
- OUT+: 反馈信号模块18-30 V DC+
- OUT-: 反馈信号模块4-20 mA输出
- *: 两个接口相互连接后设备处于低阻抗模式

> 气动接口

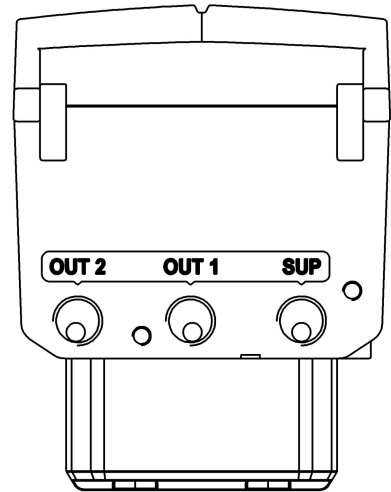

- SUP: 气源进入
- OUT1: 先导气口1
- OUT2: 先导气口2, 双作用时使用

> 接线图

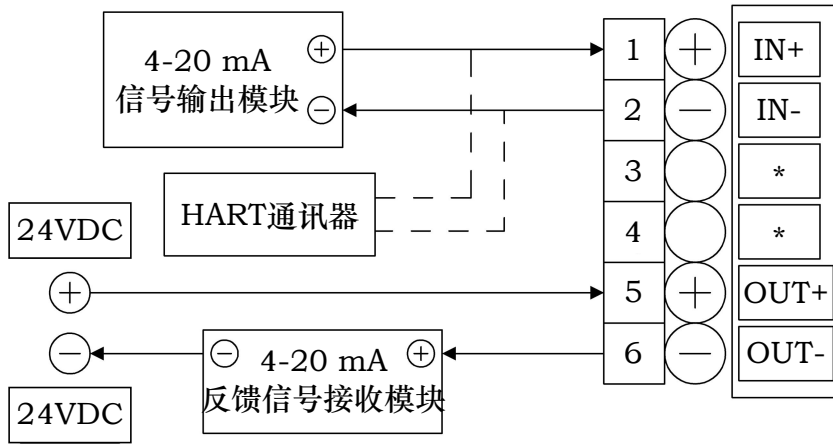

06

原理框图

Principle Block Diagram

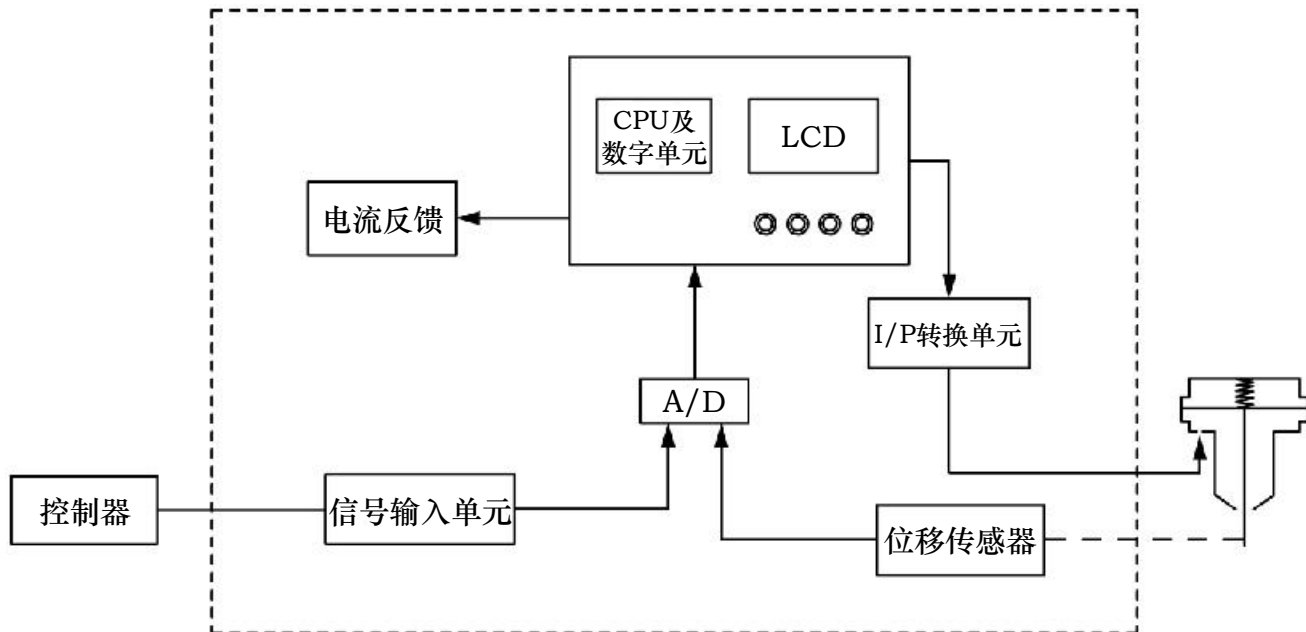

软件附加功能

- 设定信号校正
- 死区设置
- 紧闭功能
- 行程限制
- 特性曲线选择和设置
- 信号方向设置
- 行程方向设置
- 恢复出厂设置

产品优势

- IP7000系列智能阀门定位器采用微处理器和新型压电阀代替传统定位器中的喷嘴、挡板调压系统来实现对输出压力的调节控制。通过CPU运算处理来实现对阀门开度的输入信号和阀位的反馈信号的控制。压电阀由于质量小，可以释放很短的控制脉冲，从而达到很高的定位精度，且压电阀只有在阀门有偏差并执行调节动作时才耗气，所以可以实现低耗能的目的。同时因采用非接触式位移传感器，可以消除传统连杆反馈型定位器由于强烈振动造成的连杆磨损、腐蚀和损坏的问题。

07

安装组件

Mounting Components

› 直行程执行机构安装组件

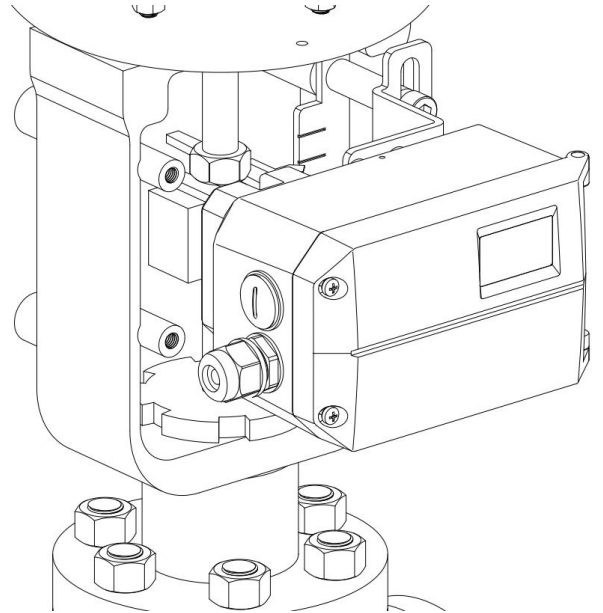
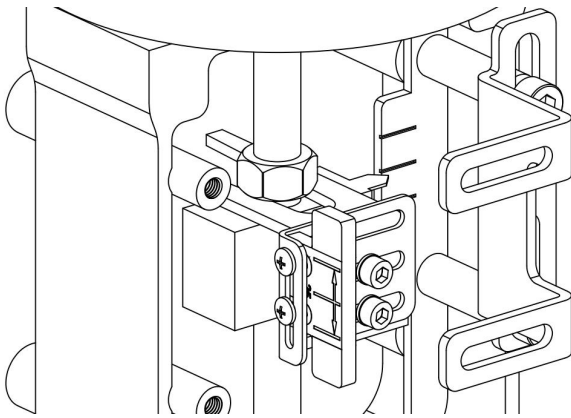

- 非接触式磁条 *1
- 磁条安装支架 *1
- M6内六角螺钉 *2
- M6弹簧垫圈 *2
- M4十字螺钉 *2

- M4弹簧垫圈 *2
- 直行程安装支架 *1
- M8六角头螺栓 *2
- M8弹簧垫圈 *2
- M8平垫圈 *2

› 角行程执行机构安装组件

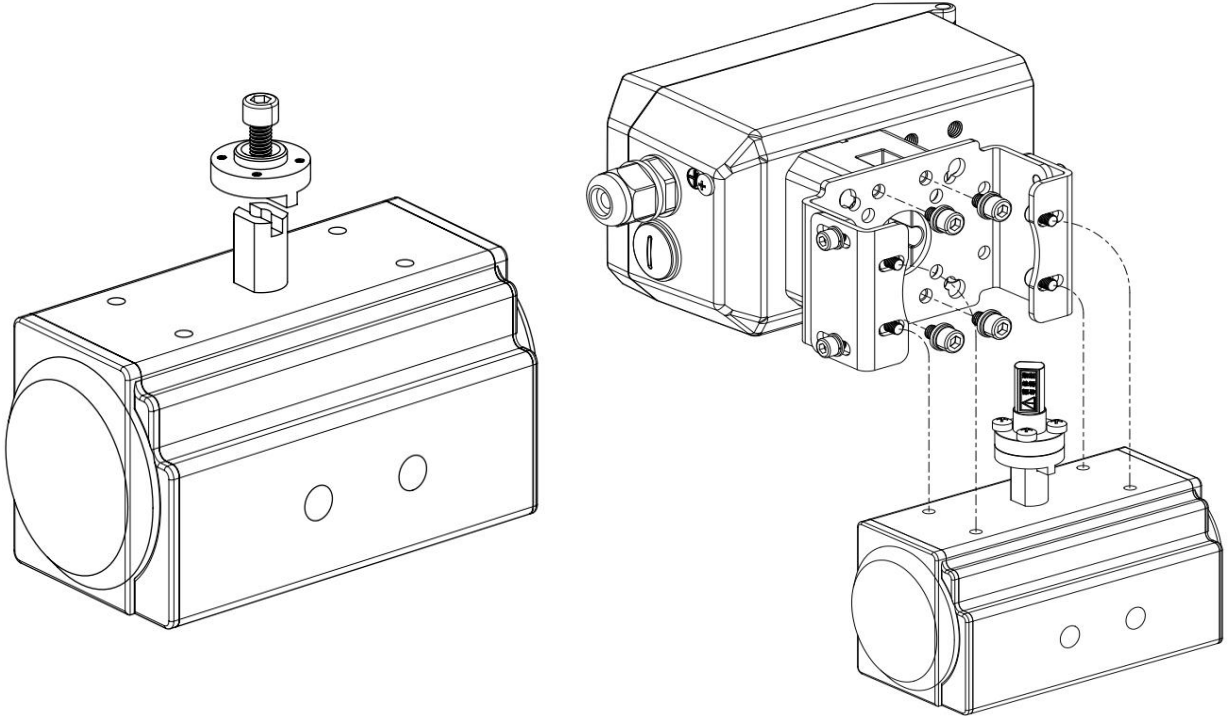

- 角行程连接件 *1
- 角行程磁条 *1
- 角行程安装支架 *1
- M6平垫圈 *4
- M6弹簧垫圈 *4

- M6内六角螺钉 *5
- M5内六角螺钉 *4
- M5弹簧垫圈 *4
- M5平垫圈 *4
- M4十字螺钉 *4

01

Technical Description



IP7000 Series Intelligent Valve Positioner

IP7000 intelligent valve positioner is mounted on pneumatic control valves. It's used to control air intake and exhaust of the pneumatic actuators to drive the valve position to the set point by calculating both data from 4-20mA DC signal and feedback position.

> Enclosure Material

- Aluminum alloy, powder coating

> Pressure Gauge Block Material

- Aluminum, anodized

> Input Signal

- Current: 4-20mA DC
- No-load Voltage: 15-24V DC
- Input Resistance: 120Ω

> Output Signal

- 2-wire 4-20mA signal

> Digital Communication Protocol

- HART 7

> Minimum Operating Current

- 3.8mA

> Steady State Air Consumption

- ≤ 0.4 L/min

> Stroke Range

- Default Linear Type: 10-110mm
- Default Rotary Type: 80-100°

> Pneumatic Data

- Air quality meets ISO 8573-1 standard
- Pressure range: 1.4-7 bar (20.3-101.5psi)
- Solid Particle Size and Density: Class 3
- Pressure Dew Point: Class 3 (minimum 20K (36° F) lower than the ambient temperature)
- Oil Content: Class 3

> Flow Rate

- Intake:

| | |
|-------|-------------------------|
| 2 bar | 4.8 Nm ³ /h |
| 4 bar | 8.0 Nm ³ /h |
| 6 bar | 11.2 Nm ³ /h |
- Exhaust (fail-safe) :

| | |
|-------|-------------------------|
| 2 bar | 5.9 Nm ³ /h |
| 4 bar | 9.8 Nm ³ /h |
| 6 bar | 13.7 Nm ³ /h |
- Exhaust (fail-freeze) :

| | |
|-------|-------------------------|
| 2 bar | 6.6 Nm ³ /h |
| 4 bar | 11.1 Nm ³ /h |
| 6 bar | 15.6 Nm ³ /h |

> Electrical Connection

- NPT 1/2 (default)
- M20 × 1.5

> Pneumatical Connection

- NPT 1/4 (default)
- G 1/4

> Protection Class

- IP66

> Vibration Resistance

- 0.15 mm, 10 Hz-60 Hz, 20 cycle/axis
- 20 m/s², 60 Hz-500 Hz, 20 cycle/axis
- Recommended range for control valve ≤ 20 m/s², no resonance peak

> Linearity & Hysteresis

- Linearity: ≤ 1.0%
- Hysteresis: ≤ 1.0%

> Ambient Temperature

- Normal Version for Non-explosion-proof:
 - 20°C ~ + 80°C
- Low Temperature for Non-explosion-proof:
 - 40°C ~ + 80°C
- Ex ia Default Type:
 - 20°C ~ + 80°C (T4/T200 135°C)
 - 20°C ~ + 40°C (T6/T₂₀₀ 85°C)
- Ex ia Low Temperature Type:
 - 40°C ~ + 80°C (T4/T200 135°C)
 - 40°C ~ + 40°C (T6/T₂₀₀ 85°C)

> Explosion-proof Grade

- Intrinsic Safety:
 - Ex ia IIC T4/T6 Ga
 - Ex ia IIIC T₂₀₀ 135°C/T₂₀₀ 85°C Da

> Intrinsically Safe Type Electrical Parameters

| Circuit Name | Max Input Voltage U_i (v) | Max Input Current I_i (mA) | Max Input Power P_i (W) | Max Internal Equivalent Parameters | |
|----------------|-----------------------------|------------------------------|---------------------------|------------------------------------|-------------|
| | | | | Ci (nF) | Li (mH) |
| 4-20 mA Input | 28 | 93 | 0.66 | ≈ 0 | ≈ 0 |
| 4-20 mA Output | 28 | 93 | 0.66 | ≈ 0 | ≈ 0 |

> Summary of Electromagnetic Compatibility Results

| Object | Description | Standard | Test Level | Result |
|------------|--|--------------|------------------------------------|--------|
| Ex ia Type | Electrostatic Discharge Immunity | GB/T 17626.2 | ± 4 kV Contact, ± 8 Kv Air | Pass |
| Ex ia Type | Radio Frequency Electromagnetic Field Radiation Immunity | GB/T 17626.3 | 3V/m, 80%AM (1kHz), 80MHz-1000MHz | Pass |
| Ex ia Type | Power Frequency Magnetic Field Immunity | GB/T 17626.8 | 50Hz, 100A/m | Pass |
| Ex ia Type | Electrical Fast Transient Pulse Group Immunity | GB/T 17626.4 | ± 1.0 kV | Pass |

> Rated Conditions-height

- 2000m above sea level
- At locations above 2000m above sea level, please use a suitable power supply

> Rated Conditions-installation Position

- Anywhere
- In a humid environment, the pneumatic connector and exhaust port are not facing upwards, please install correctly

> Position Feedback Module

For Position Feedback DC Output, 2-wire Connection

| | |
|-----------------------------------|--|
| Current Output | Terminals OUT1 and OUT2 |
| Output Rated Signal Range | 4-20mA, short-circuit proof |
| Dynamic Range | 3.8-20.5mA |
| External Load R_B [k Ω] | $\leq (U_{Aux}[v]-12v) I$ [mA] |
| Transmission Error | $\leq 0.5\%$ |
| Temperature Effect | $\leq 0.1\%/10K$ ($\leq 0.1\%/18^\circ F$) |
| Resolution | $\leq 0.1\%$ |
| Effective Internal Capacitance | C_i =Approximately 0 |
| Effective Internal Inductance | L_i =Approximately 0 |

02

Advantages & Applications

> Advantages

- Simple mounting and one-key automatic commissioning
- Mature and reliable piezo module, imported from Germany
- Simple operation and configuration of the device using 4 buttons and LCD local display
- Numerous functions can be activated(e.g. characteristic curves and limits)
- Negligible air consumption in stationary operation
- Tight closing function
- Fail-freeze function (Optional according to product selection chart)
- One device variant for linear and rotary actuators
- Excellent shock resistance
- On-site calibration of 4-20 mA input signal can be performed
- Non-contact displacement sensor

> Applications

- Refining / Petrochemical / Nuclear Power / Power Plant
- Paper and glass / water and wastewater industry
- Food & beverage, pharmaceutical industry
- Marine Industry

03

Mechanical Dimensions

> IP7000 Series Intelligent Valve Positioner Mechanical Dimensions

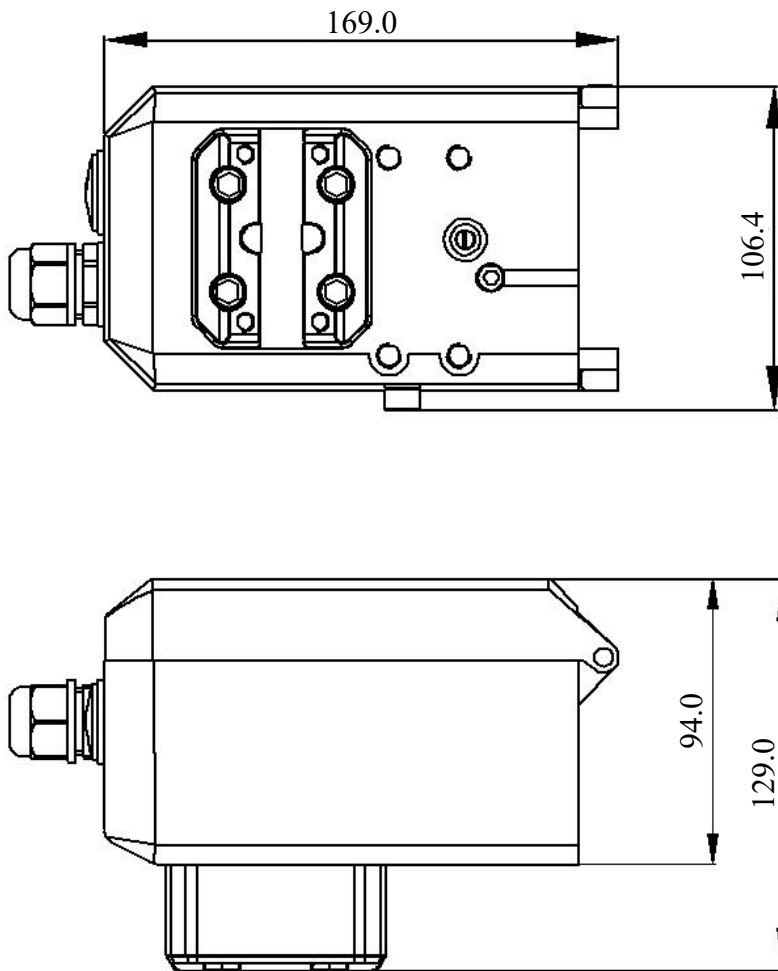

> **25mm Magnetic Strip (suitable for a stroke range of 10-25mm)**

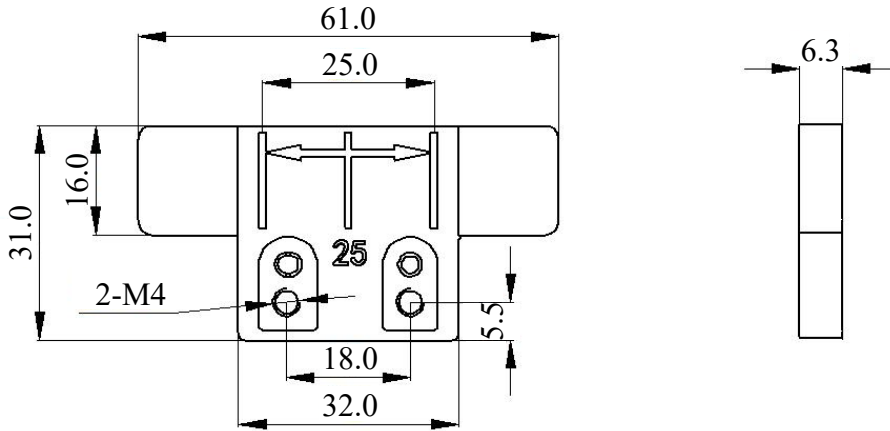

> **38mm Magnetic Strip (suitable for a stroke range of 25-38mm)**

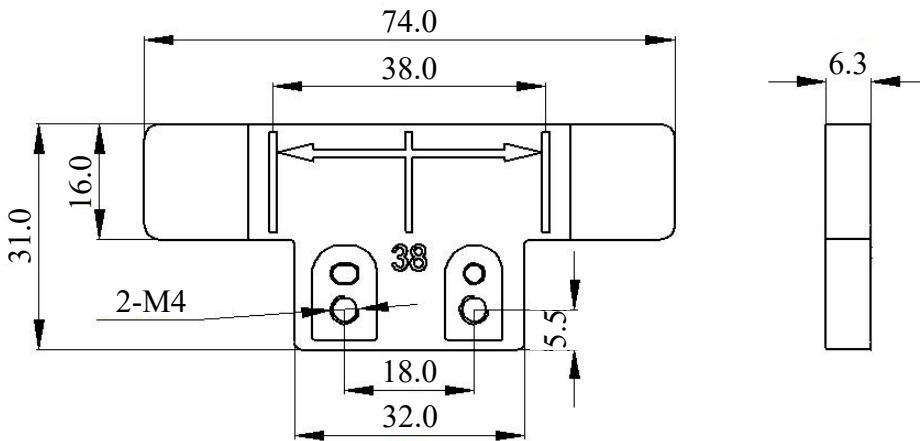

> **50mm Magnetic Strip (suitable for a stroke range of 38-50mm)**

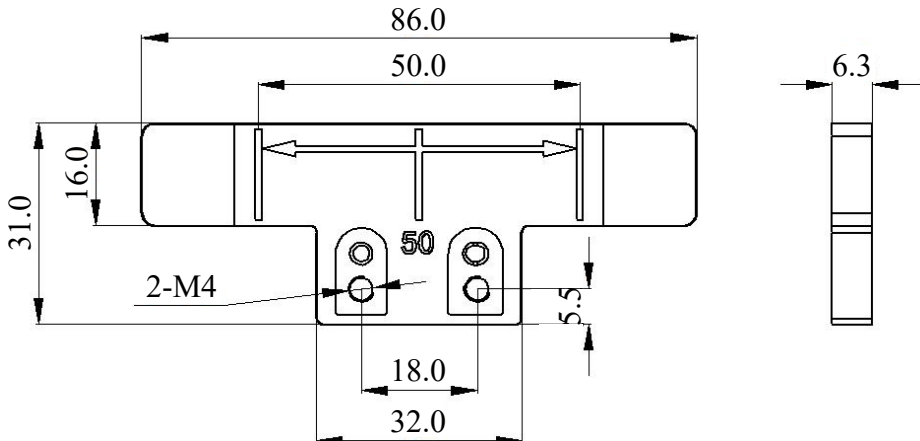

> **110mm Magnetic Strip (suitable for a stroke range of 50-110mm)**

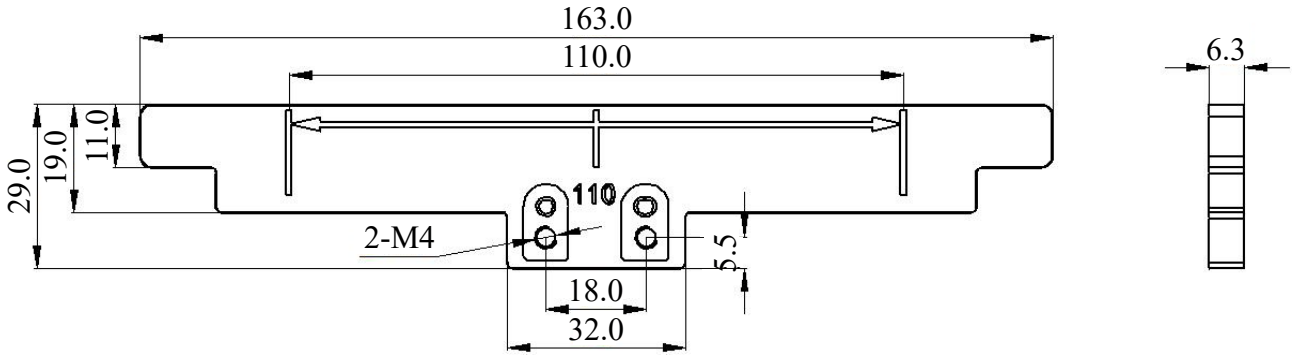

> **Outline Drawing of Rotary Magnetic Strip**

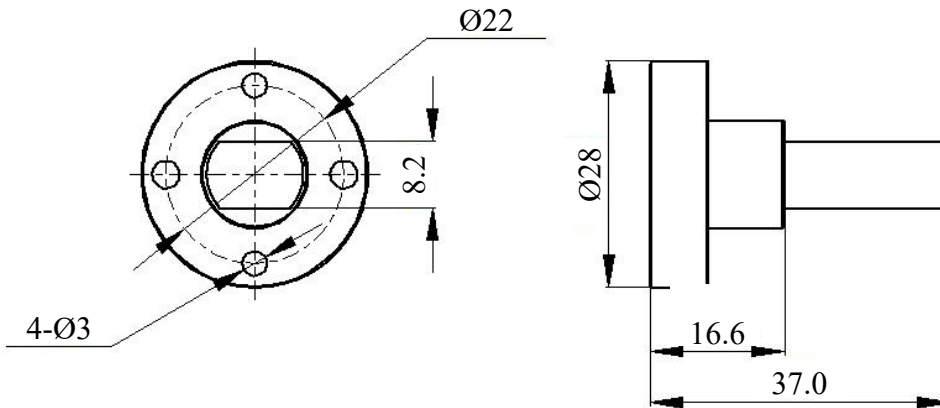

> **Rotary Magnetic Strip Connector**

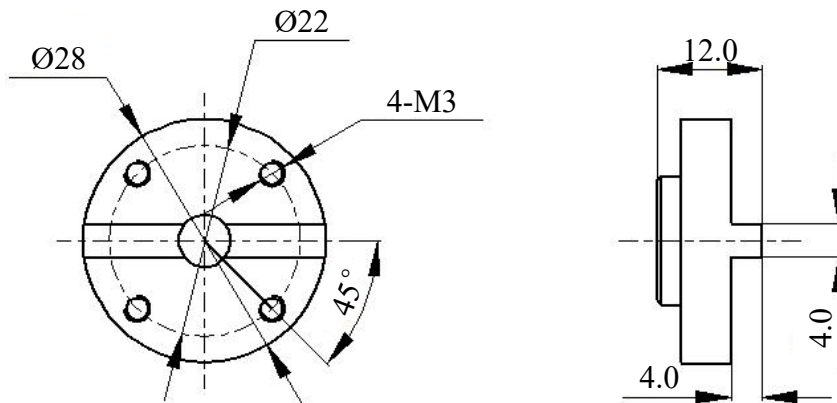

> **Linear Mounting Bracket**

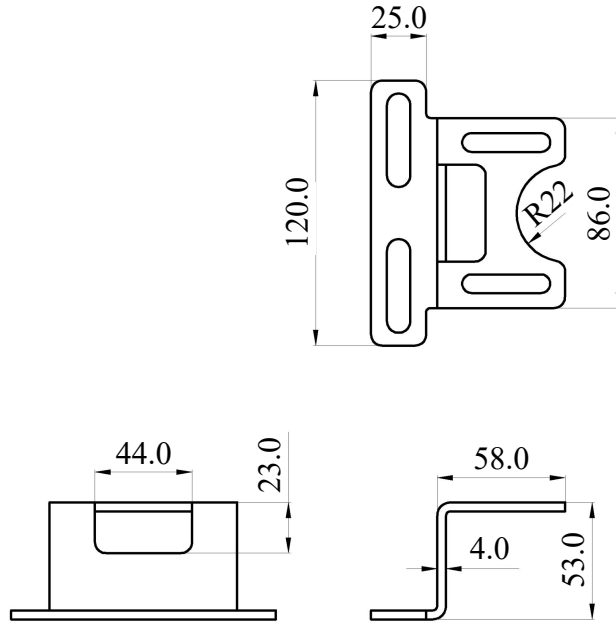

> **Rotary Mounting Bracket - Form 1**

> **Rotary Mounting Bracket - Form 2**

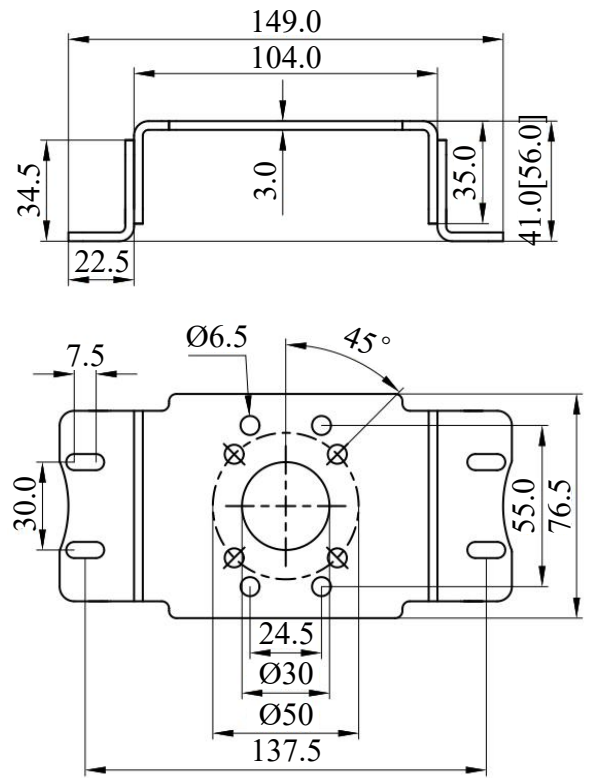
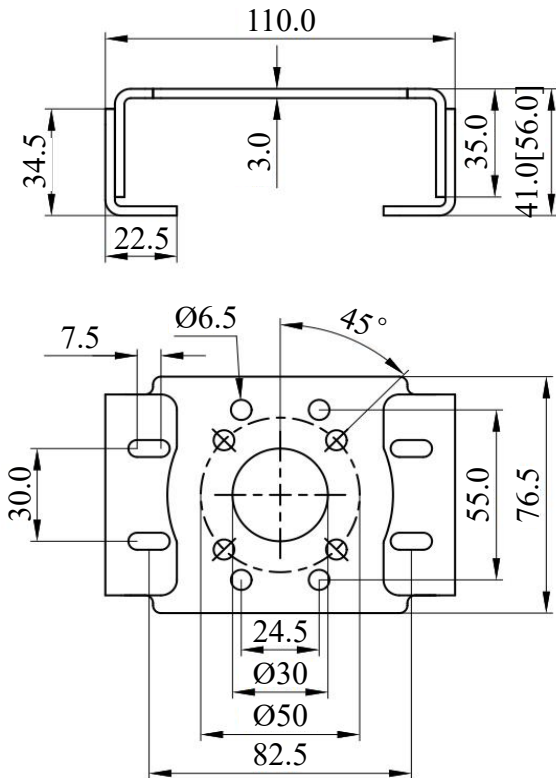

04

Product Structure

> IP7000 Series Intelligent Valve Positioner Product Structure

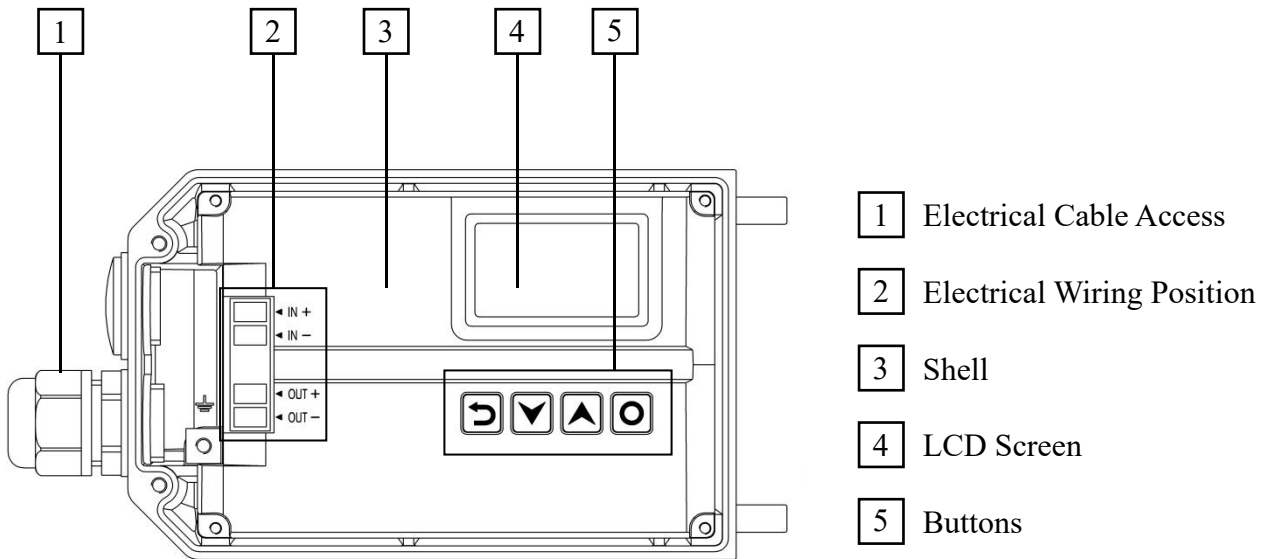

05

Electrical & Pneumatic Connections, Wiring Diagram

> Electrical Connections

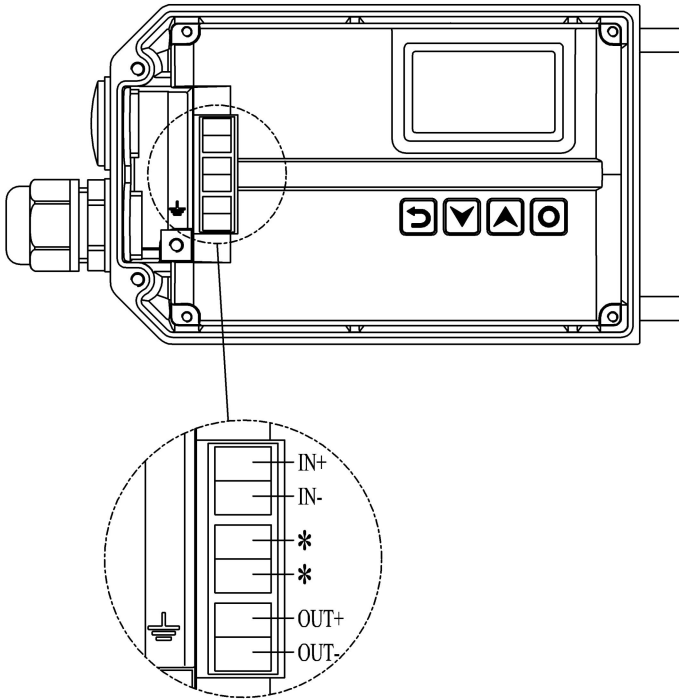

- IN+: 4-20 mA input signal +
- IN-: 4-20 mA input signal -
- OUT+: Feedback signal module 18-30 V DC +
- OUT-: Feedback signal module 4-20mA output
- *: The two interfaces are connected with each other, and the device is in low impedance mode

> Pneumatic Connections

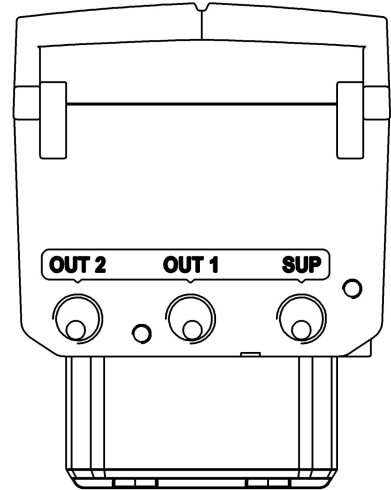

- SUP: Air supply enter
- OUT1: Pilot air outlet 1
- OUT2: Pilot air outlet 2, used for double acting type

> **Wiring Diagram**

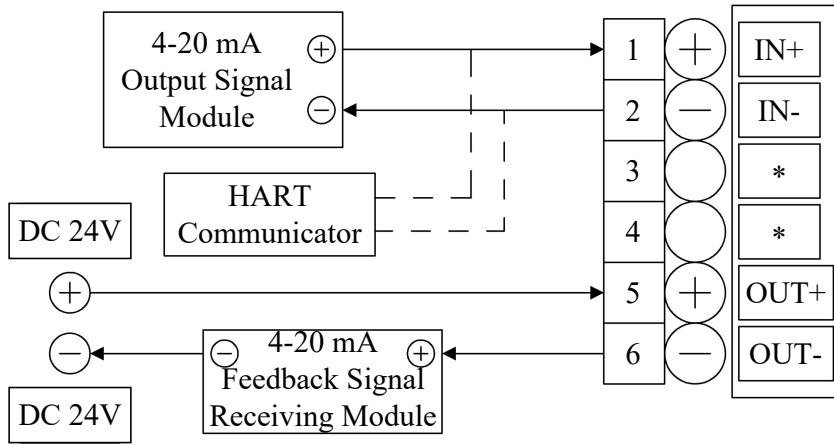

06

Principle Block Diagram

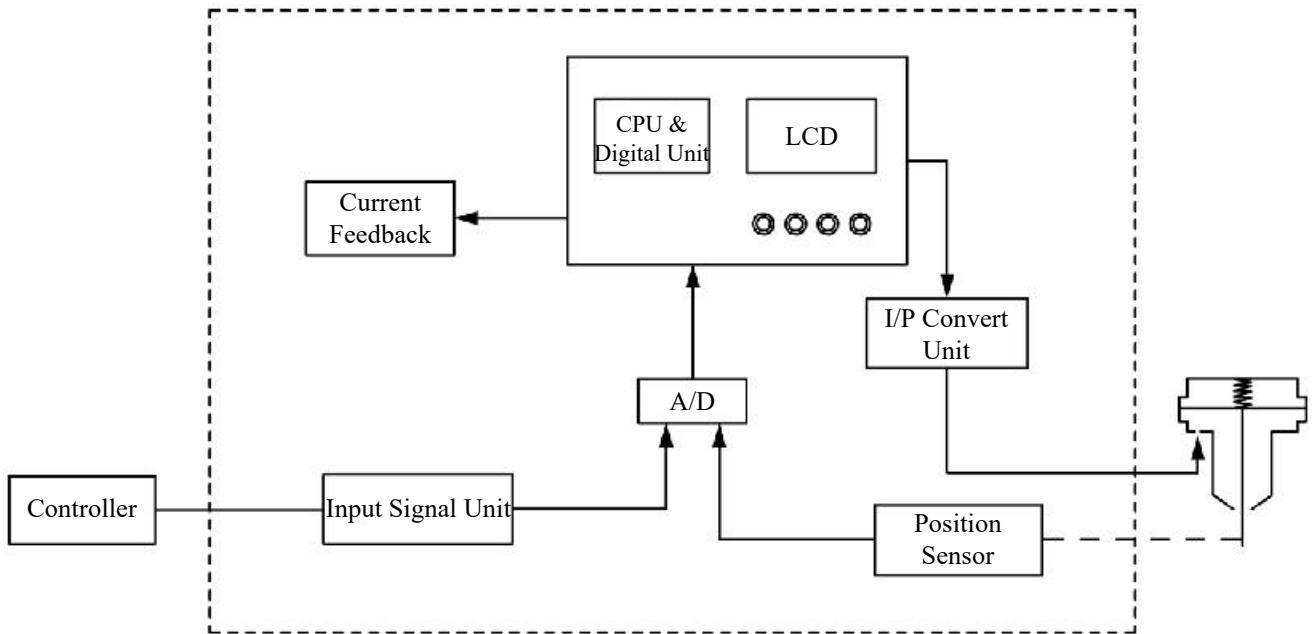

> Additional Software Functions

- Calibrating the input signal
- Calibrating the set-point signal
- Tight closing function
- Stroke limit function
- Characteristic curve selection and settings
- Selection of signal direction.
- Selection of stroke direction.
- Reset function

> Advantages

- The IP7000 intelligent valve positioner uses a microprocessor and advanced piezo valve instead of the conventional nozzle-baffle system to control output pressure. It processes input and position feedback signals via CPU for accurate valve control. The lightweight piezo valve generates short control pulses for high precision, and consumes air only when a valve deviation occurs and adjustment is performed, ensuring low air consumption. Additionally, the non-contact displacement sensor eliminates rod wear, corrosion and damage caused by severe vibration in traditional linkage feedback positioners.

07

Mounting Components

> Linear Actuator Mounting Components

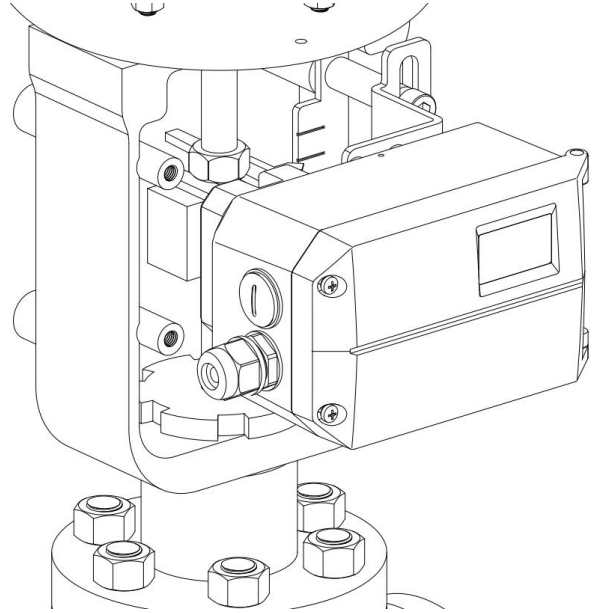
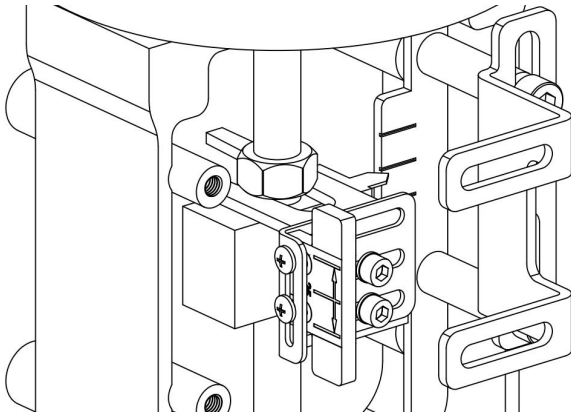

- Non-contact Magnetic Strip *1
- Magnetic Strip Mounting Bracket *1
- M6 Hexagon Socket Screw *2
- M6 Spring Washer *2
- M4 Cross Recessed Screw *2

- M4 Spring Washer *2
- Linear Mounting Bracket *1
- M8 Hexagon Head Bolt *2
- M8 Spring Washer *2
- M8 Flat Washer *2

> Rotary Actuator Mounting Components

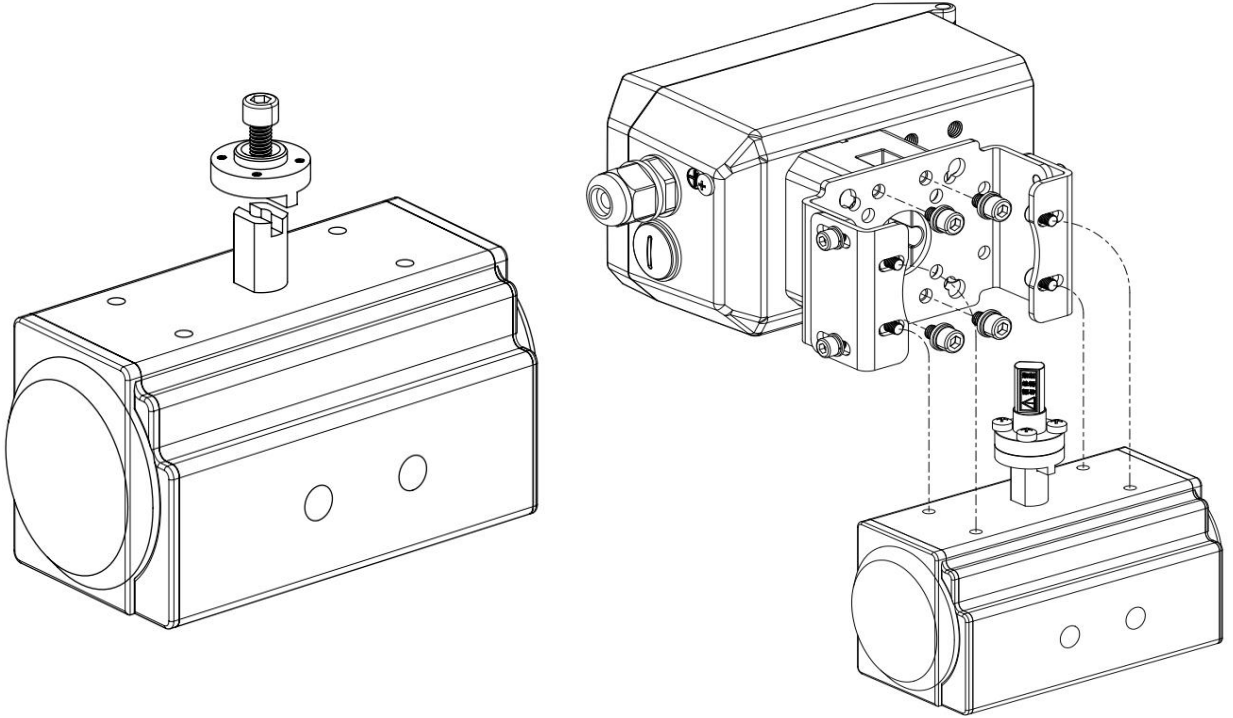

- | | | | |
|---------------------------|----|---------------------------|----|
| • Rotary Connector | *1 | • M6 Hexagon Socket Screw | *5 |
| • Rotary Magnetic Strip | *1 | • M5 Hexagon Socket Screw | *4 |
| • Rotary Mounting Bracket | *1 | • M5 Spring Washer | *4 |
| • M6 Flat Washer | *4 | • M5 Flat Washer | *4 |
| • M6 Spring Washer | *4 | • M4 Cross Recessed Screw | *4 |

